

KSTAR



Industrial and Commercial Power Inverters KAC50DP

User manual

Shenzhen Kstar New Energy Co., Ltd.

V1.0

Index

1	About this manual	1
1	1.1 Introduction	1
1	1.2 Applicable products.....	1
1	1.3 Product model naming rules	1
1	1.4 Description of the manual	1
1	1.5 Description of signals.....	1
2	Safety instructions.....	3
2	2.1 Personnel requirements	3
2	2.2 Operation of safety warnings	3
2	2.3 Protection of symbols on the equipment	3
2	2.4 Electrical safety issues	4
2	2.5 Environmental space requirements	5
2	2.6 Live Test Specifications	5
2	2.7 Setting parameters	5
2	2.8 Maintenance or overhaul specifications.....	6
2	2.9 Product scrapping	6
2	2.10 Other precautions	6
3	Product presentation	7
3	3.1 Power inverter	7
3	3.2 Product appearance.....	8
3	3.3 Main power topology	9
3	3.4 Product Features	9
3	3.5 Communication scheme.....	10
4	PCS Modes and Functions	11
4	4.1 Introduction to the modes.....	11
4	4.2 PCS Functions	11
4	4.3 Introduction to the PCS states	12
5	Mechanical Installation Guide	13
5	5.1 Precautions before installation.....	13
5	5.2 Installation process	13
5	5.3 Preparing for installation.....	14
5	5.4 Transporting the machine	17
5	5.5 Positioning and fixing.....	18
5	5.6 Air duct design and installation	19
6	Electrical installation instructions.....	21
6	6.1 Cable requirements.....	21

6 .2 Wiring specifications.....	2 2
6 .3 Securing and protecting the connection cables.....	2 2
6 .4 DC side wiring.....	2 4
6 .5 AC side wiring.....	2 6
6 .6 Communication interface	2 8
6 .7 Grounding the system	2 9
6 .8 Complete installation	2 9
7 Commissioning.....	3 0
7 .1 Check before starting.....	3 0
7 .2 Power On/Off Process.....	3 1
7 .3 Fault shutdown procedure	3 1
8 Maintenance and troubleshooting.....	3 3
8 .1 Description	3 3
8 .2 Precautions	3 3
8 .3 Troubleshooting	3 5
Appendix 1 : Technical parameters	3 9
Appendix 2 : Quality Assurance.....	4 2
Appendix 3 : Terminological interpretation.....	4 3



About this manual

1 .1 Introduction

Dear user, thank you for using the power inverter developed and manufactured by Shenzhen Kstar New Energy Co., Ltd. We sincerely hope this product meets your needs. We also look forward to your valuable feedback on the performance and features of this product. We will continue to improve.

1 .2 Applicable products

This manual is for Shenzhen Kstar New Energy Co., Ltd. industrial and commercial power inverter: KAC50DP

※Unless otherwise specified, all references to “PCS” and “power inverter” in this manual refer to this series of products.

1 .3 Product model naming rules

Field 1	Field 2	Field 3	Field 4	Field 5	Field 6	Model of system
K	TO	C	5 0	D	P	KAC50DP
KSTAR	CA	Inverter	Diet	Outdoor	PV	

1 .4 Description of the manual

➤This manual is a special instruction manual for the KAC50DP series provided by Shenzhen Kstar New Energy Co., Ltd.. The manual provides detailed product information, installation, operation, maintenance, and troubleshooting instructions. Before installing and operating the equipment, read and understand all instructions in this manual and familiarize yourself with the relevant safety symbols.

➤The reader should have some knowledge of electrical theory, electrical wiring, and equipment. Before installing the product, read this manual carefully and ensure that relevant personnel can easily access and use it.

➤The content, images, logos and symbols used in this manual are the property of Shenzhen Kstar New Energy Co., Ltd.. Public reproduction of all or part of the content without the written permission of Kstar is prohibited.

1 .5 Description of signals

In order to ensure the personal and property safety of users when using this product, and for better use of the product itself, relevant information is provided in the manual and highlighted with appropriate symbols.

The following are symbols that may be used in this manual. Please read carefully.



DANGER!

Danger

Indicates a situation with a high degree of potential risk, which, if not avoided, could result in death or serious injury.



WARNING!

Warning

Indicates a situation with moderate potential risk which, if not avoided, could result in death or serious injury.



YOU DO
ATTENTION!

I notify

Indicates the presence of a potential low-level hazard which, if not avoided, may result in minor or moderate injury to personnel.



NOTE!

Attention

Indicates the existence of a potential risk which, if not avoided, may result in the equipment not functioning properly or a fault being reported.



The “description” highlights and complements the content and can also provide techniques to optimize the use of the product.

Always pay attention to the danger symbols on the equipment. These symbols include:

Symbol	Description
	This symbol indicates that the equipment contains high voltage inside and that touching it may cause electric shock.
	This symbol indicates that the temperature at this point is above the acceptable range for the human body. Do not touch it to avoid personal injury.
	This symbol indicates the protective earth (PE) terminal, which must be connected to earth to ensure operator safety.

2

Safety instructions

2.1 Staff requirements

- Only professional electricians or qualified personnel should perform any work on this product.
- Operators must be fully familiar with the structure and working principle of the entire power inverter.
- Operators must be fully familiar with this KAC50DP Power Inverter User Manual.
- Operators must be fully familiar with the relevant regulations of the country/region in which the project is located.



WARNING!

Warning

- It is strictly forbidden to carry out maintenance or overhaul operations when the equipment is under voltage!
- During maintenance or overhaul of the equipment, at least one person must be present on site. **two operators** Maintenance or overhaul operations may only be performed when the equipment has been safely disconnected and the power inverter has discharged after 10 minutes.

2.2 Operation of safety warnings

During installation, daily maintenance, and inspection of the power inverter, observe the following to prevent unauthorized personnel from approaching and causing malfunctions or accidents:

- Install clearly visible signs at the front and rear switches of the power inverter to prevent accidental switching.
- Install warning signs or seat belts near the operating area.
- After maintenance or overhaul, be sure to lock the top cover.

2.3 Protection of symbols on the equipment

- The warning symbols on the power inverter contain important information for safe operation of the power inverter. It is strictly prohibited to tear off or damage the symbols!
- A nameplate is installed inside the front door of the power inverter. The nameplate contains important product parameters. Tearing or damaging the nameplate is strictly prohibited!
- If any symbol is damaged or blurred, please contact Shenzhen Kstar New Energy Co., Ltd.



Attention

- Ensure that the symbols on the body of the equipment are always clear and legible.
- If a symbol is damaged or obscured, it must be replaced immediately.

NOTE!

2 .4 Electrical safety issues

2 .4.1 Electrical safety



DANGER!

Danger

Make sure the equipment is properly grounded before use!



DANGER!

Danger

There is a lethal high voltage inside the product!

- Do not touch the terminals or conductors connected to the mains circuit.
- Pay attention to all instructions or safety documents relating to connection to the mains and follow the warning symbols on the product.
- Observe the safety precautions listed in this manual and other documents related to this equipment.



DANGER!

Danger

Damaged equipment or system failure can cause electric shock!

- Before operation, visually inspect the equipment for damage or other hazards.
- Check that other external equipment or circuit connections are secure.
- Confirm that the equipment is in a safe state before operation.

2 .4.2 Electrostatic safety



NOTE!

Attention

Electrostatic-sensitive components on the circuit board or elsewhere can be damaged by improper operation or contact by the operator.

- Operators are required to avoid unnecessary contact with the circuit board.
- Operators are required to comply with electrostatic protection regulations, for example by wearing an ESD wrist strap.

2 .5 Environmental space requirements

2 .5.1 Requirements for escape passage

To ensure that the operator can quickly evacuate the scene in the event of an accident, observe the following:

- Do not place flammable or explosive materials around the power inverter.
- It is strictly prohibited to pile up debris in the escape passage or to occupy the escape passage in any way.

2 .5.2 Moisture protection

Do not open the lid in case of high humidity or rain!

2 .6 Live test specifications

2 .6.1 Measurement under voltage



DANGER!

Danger

The equipment is equipped with high voltage. Accidental contact can cause fatal electric shock. Therefore, when measuring under voltage, be sure to:

- Use adequate protection (e.g. wear insulating gloves, insulating shoes, etc.)
- At least two operators must be present on site to ensure personal safety.

2 .6.2 Use of measuring equipment

To ensure that the electrical parameters comply with the requirements, it is necessary to use the relevant electrical measuring equipment when carrying out the electrical connection and test operation of the power inverter.



WARNING!

Warning

- Select high-quality measuring equipment that meets site requirements, such as flow rate and applicable conditions.
- Ensure that the connection and use of measuring equipment is correct and standardized to avoid electric arcs and other hazards.

2 .7 Setting parameters

The parameters are closely related to the operation of the power inverter. The operating conditions of the system and the power inverter must be reliably analyzed and evaluated before these parameters can be changed. The specific parameters are set in the background (PC or EMS).



WARNING!

Warning

- Inappropriate parameter settings may impair the normal operation of the power inverter!
- Only authorized professionals can set the parameters of the power inverter.

2 .8 Maintenance or overhaul specifications

Pay attention to the following points when carrying out maintenance or overhaul of the equipment:

- Make sure that the power inverter is not accidentally powered on.
- Use a multimeter to verify that the internal discharge of the power inverter has been completed.
- Make sure the equipment is properly grounded.
- Live parts must be insulated and covered with insulating materials.
- The top cover can be opened for maintenance or inspection of the power inverter after at least 10 minutes, when the power inverter has been turned off and the AC-DC power supply has been disconnected.
- Throughout the entire maintenance and inspection process, it is necessary to ensure that the escape passage is completely clear.

2 .9 Product scrapping

- When the power inverter needs to be disposed of, it must not be treated as conventional waste.
- Contact your local authorized professional recycling agency.

2 .10 Other precautions

The summary of actual operation shall be based on site needs and the following protective or emergency measures shall be adopted:

- When performing maintenance, inspections and other operations, personnel must take necessary protective measures, such as wearing noise-proof earplugs, insulating shoes and anti-scald gloves.
- Power inverters are usually installed far from urban areas. Relevant emergency facilities must be provided if necessary.
- Take all necessary auxiliary measures to ensure the safety of personnel and equipment.



NOTE!

Attention

All operations on the power inverter must comply with the relevant regulations of the country/region in which it is located.



All descriptions in this manual refer to the standard configuration of the power inverter. If you have any special requirements, please inform the staff at Shenzhen Kstar New Energy Co., Ltd. For details, please refer to the actual product you received.

This manual cannot cover all possible situations in the operation, maintenance, and inspection processes. If you have any questions, please contact Shenzhen Kstar New Energy Co., Ltd. promptly.



3

3 .1 Power inverter

On the power generation side, the power inverter (PCS) can effectively connect renewable energy generation, such as solar and wind power, to the power grid. On the transmission side, it can respond to the power grid and implement peak-frequency modulation and peak-load shifting to coordinate with grid dispatching and stabilize the power grid frequency. When used on the power distribution side, it can implement peak-load shifting to alleviate energy shortages during peak power consumption periods and mitigate waste caused by excess electricity when power consumption is low. On the power consumption side, it can be used as a large uninterruptible power supply. It can control the battery charging and discharging process, perform AC/DC conversion, and directly supply power to the AC load without the power grid. The PCS consists of a bidirectional AC/DC inverter, a bidirectional DC/DC inverter, a MPPT inverter, and a control unit, etc. The PCS controller receives the underlying control command through communication and controls the inverter to charge or discharge the battery based on the symbol and size of the power command, thus achieving grid active and reactive power regulation. The PCS controller communicates with the BMS via the CAN interface to obtain battery pack status information, thus implementing protective battery charging and discharging and ensuring its safe operation.

3.2 Product appearance

The appearance of the power inverter and the introduction of external components are illustrated in the following figures:

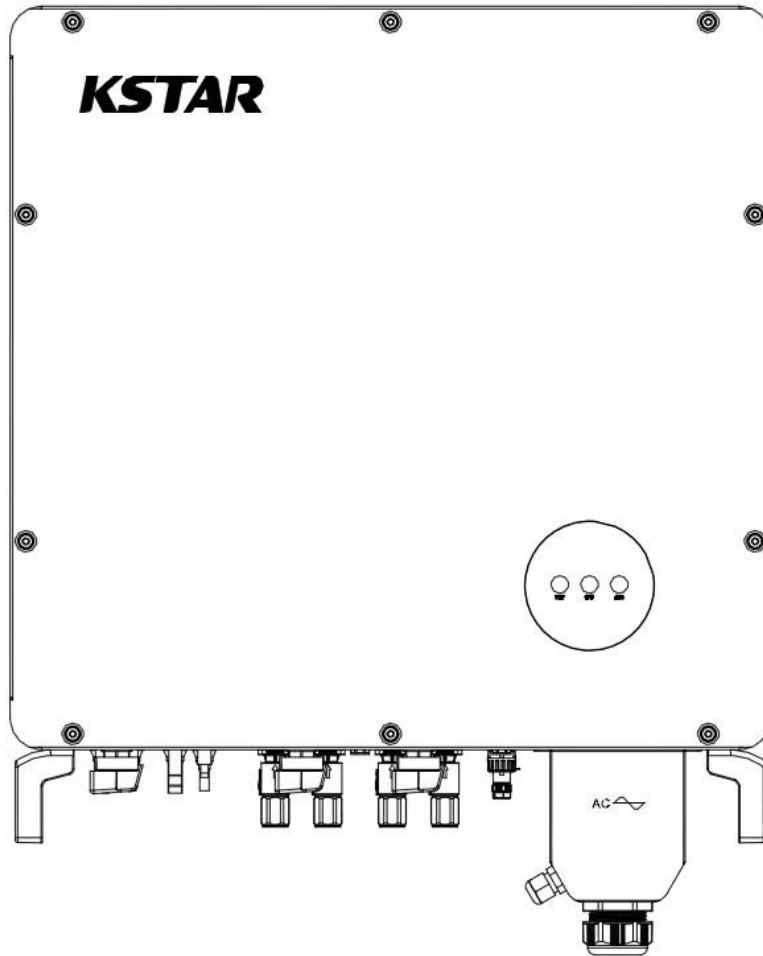

Figure 3 -1 Front view of the KAC50DP

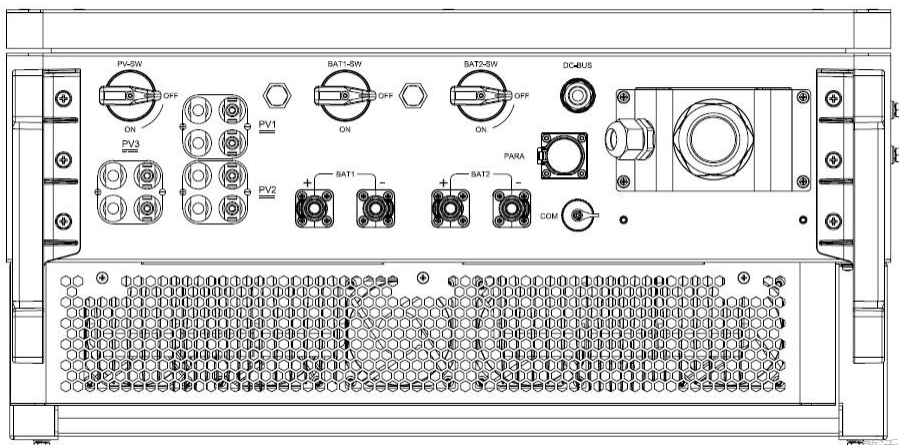
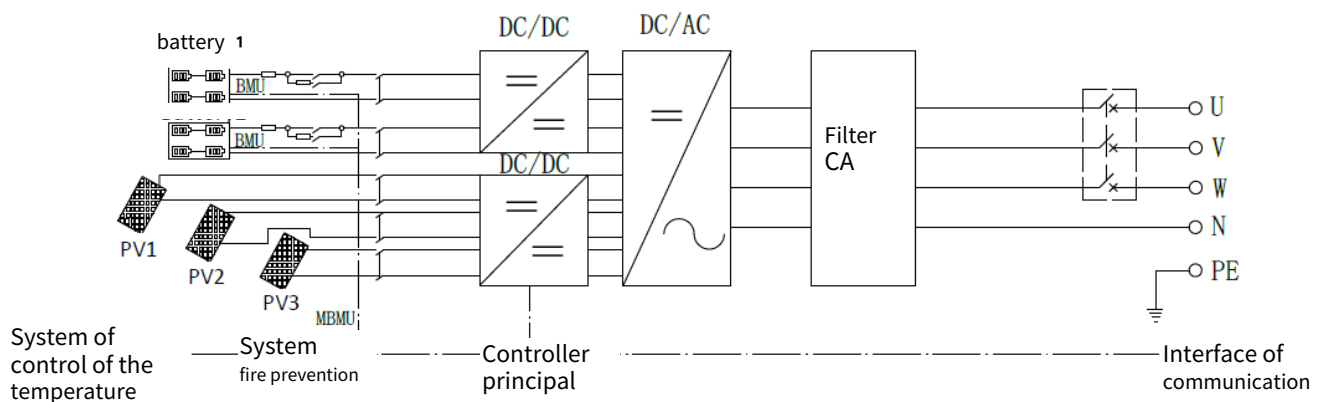

Figure 3 -2 Bottom view of the KAC50DP

3.3 Main power topology

The PCS adopts a staggered two-phase BOOST-BACK+T type three-level topology to realize four-quadrant operation; the filter circuit adopts an LCL filter circuit.

The main circuit principle of the power inverter is illustrated in the following figures:



3.4 Product Features

The KAC50DP power inverter uses advanced digital control technology to optimize control performance and improve system reliability. It is suitable for various battery charging and discharging needs, and its main performance characteristics are as follows:

- It accepts power grid dispatching, the communication method includes CAN, RS485, etc.
- Multiple working modes, such as on-grid, off-grid and hybrid modes.
- Transformer with STS switching cabinet
- Independent and controlled regulation of frequency and voltage.
- With the grid-independent inverter function, the power inverter creates a microgrid to ensure the power supply of important loads.
- Off-grid with strong three-phase unbalanced load capacity, 100% single-phase.
- High frequency, high power density design scheme.
- Using dual AC/DC auxiliary power mode to improve reliability.
- Independent air duct, excellent heat dissipation.

3 .5 Communication scheme

3 .5.1 Basic communication scheme

The PCS communicates with the EMS via RS485 and the EMS communicates with the PC via Ethernet and is monitored by the self-designed ESS monitoring software.

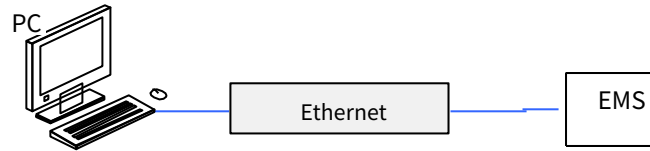

Figure 3 -4 Monitoring your PC via Ethernet

3 .5.2 EMS communication scheme

Through the RS485 communication line, the PCS can communicate with the EMS and can be monitored in real time by the self-designed ESS monitoring software.

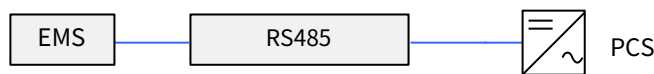

Figure 3 -5 EMS monitoring via RS485

3 .5.3 BMS communication scheme

Through the CAN communication line, the PCS can communicate with the BMS to realize data transmission.

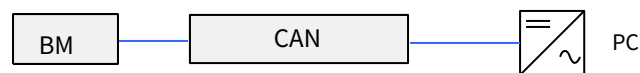

Figure 3 -6 The BMS transmits data via CAN

4

PCS modes and functions

4 .1 Introduction to the modes

4 .1.1 On-grid and off-grid modes

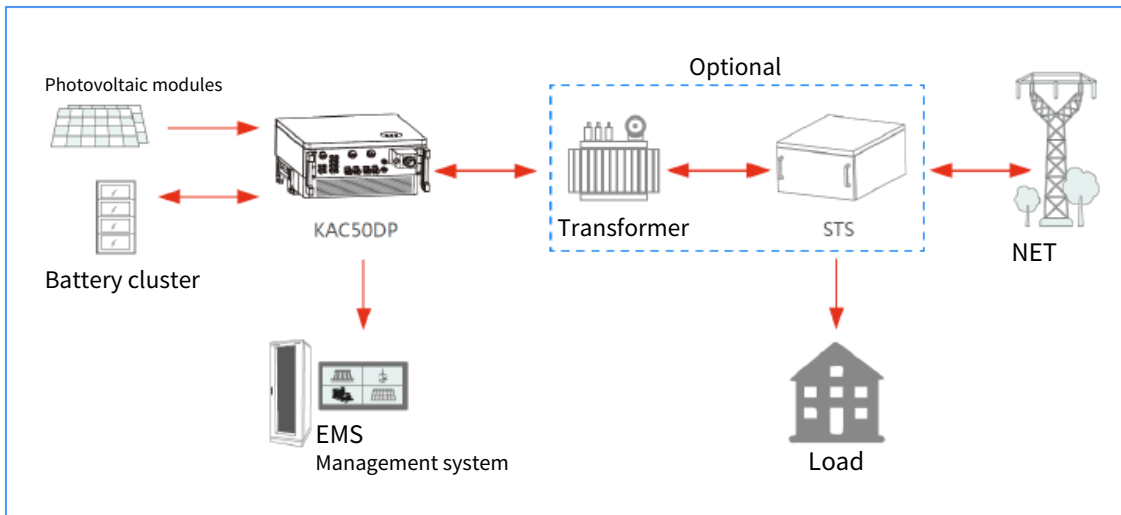

Figure 4 -1 System block diagram

On-grid mode: connected to the public grid, it follows the amplitude/phase and frequency of the grid voltage, with islanding protection.

Off-grid mode: In the island state, the PCS operates in voltage source mode and outputs a certain voltage and frequency.

On-grid mode, off-grid mode: According to the local power grid situation, manually set the working mode of the PCS.

4 .2 Functions of the PCS

4 .2.1 Basic functions

■ Self-consumption:

The electricity generated by photovoltaics is stored or used directly by the load.

■ Off-peak power consumption:

During the workday, the load is powered primarily by photovoltaic and battery power to avoid draining the grid's peak power; on weekends, the grid supplies power and stores energy for the load.

■ Peak trimming and valley filling:

Thanks to photovoltaics and ESS, energy demand for the grid is reduced during peak energy consumption periods and increased during minimum periods.

■ Controlling the charge and discharge of the energy storage battery

All KAC50DP models can be charged and discharged in on-grid mode. The charge and discharge depth can be set by the user.

4 .2.3 Starting the cooling system

The cooling system starts automatically when the PCS reaches a certain power or the temperature reaches a threshold, and the speed is continuously adjusted.

4 .3 Introduction to the PCS states

The PCS has 5 states in total, as shown in Table 4 -1:

Table 4 -1 Status and description

State	Description	LED status
Self-test	When the DC side switch is turned on, the DC side of the inverter performs a self-test to detect whether the DC side voltage is normal.	The yellow light is flashing The red light is flashing
Standby	After the self-test is completed, the DC side enters the softstart state; after the softstart is completed, the DC contactor closes and the inverter is in standby mode.	The yellow light stays on The red light stays on
On-grid	After the system is in standby mode, if the power grid is normal at this time, the user can use the EMS or PC to set the inverter's operating mode to on-grid mode. When the inverter receives the start command from the EMS or PC, the AC-side relay closes and the system enters the on-grid operating state.	The green light stays on
Off-grid	After the system is in standby mode, the user can use the EMS or PC to set the inverter's operating mode to off-grid mode. When the inverter receives the start command from the EMS or PC, the AC-side relay closes and the system enters the off-grid operating state.	The green light stays on
Broken down	All PCS relays are disconnected and the system stops working.	The red light stays on



WARNING!

Warning

When the PCS fails, it is prohibited to turn it on again.

Turn off the power and check that there are no problems before turning it back on, otherwise you risk damaging the machine.

5

Mechanical Installation Guide

5 .1 Precautions before installation

➤Installation of this series of PCS requires at least two qualified personnel, and the electrical installation must comply with local regulations. Care must be taken to avoid falls and breakages.

➤During installation, do not touch any other parts inside the frame except the wiring terminals.

➤Safety signs “Work in Progress! Do Not Switch On!” must be posted on all switches upstream of the inverter.

5 .2 Installation process

The installation process of the KAC50DP power inverter is as follows:

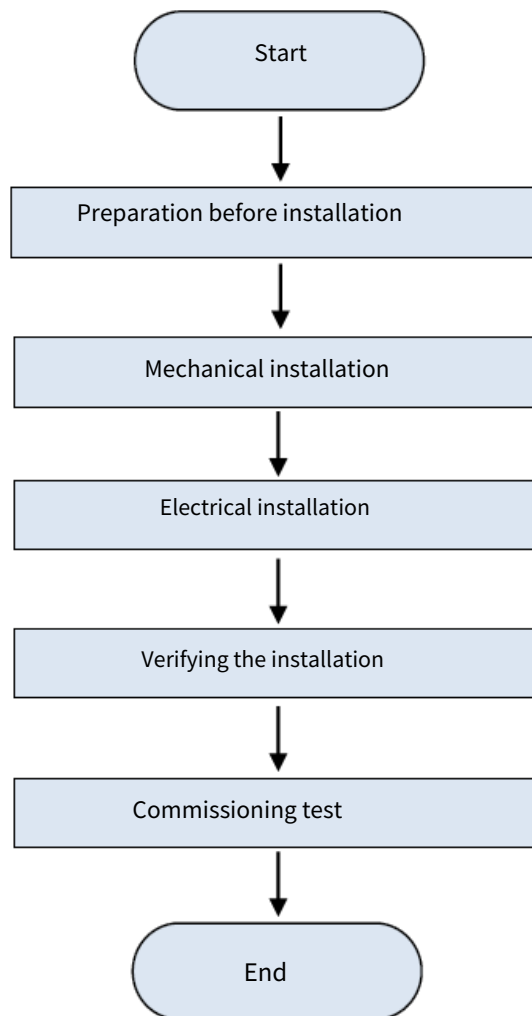

Figure 5 -1 Installation flowchart

5.3 Preparing for installation

5.3.1 Packaging inspection

Before installation, check the equipment for damage. If you find any damage during transportation, contact the shipping company or Shenzhen Kstar New Energy Co., Ltd. and provide a photo of the damage.

5.3.2 Checking the delivery list

Based on the packing list in the box, check whether all the delivered accessories are complete and intact:

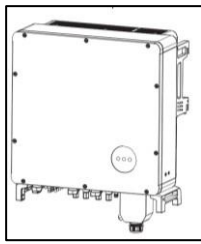

Inverter



User manual



Certificate



Guarantee card

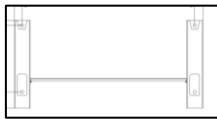

Mounting bracket

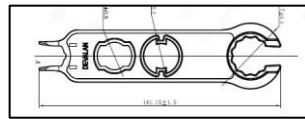

PV key

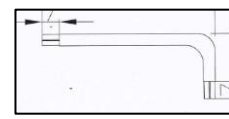

L-wrench

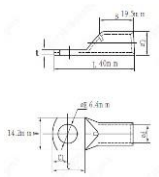

CA OT Terminal



M10 bolt



M6 combined screw



Recovery key

Figure 5 -2 Delivery scheme

Table 5 -1 Delivery list

N.	Voice	Amount
1	Inverter	1 pc
2	User manual	1 pc

3	CA OT Terminal	5 pcs
4	Certificate	1 pc
5	Guarantee card	1 pc
6	Mounting bracket (2 mounting bracket assemblies and 1 mounting rod) connection)	1 pc
7	Bolt (M10*35)	4 pcs
8	Nut (M10)	4 pcs
9	Combination screw (M6*16)	2 pcs
1 0	Key (for removing the PV connector)	1 pc
1 1	L-key (for removing the cover)	1 pc
1 2	Special reset key for PV switch	1 pc

5 .3.3 Checking the parts list

When the inverter is shipped separately, the following optional parts are not included. If the customer requires them, they must be purchased separately.

Note: Does not include cable.



Terminal of the drums

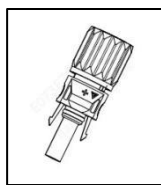

PV positive terminal

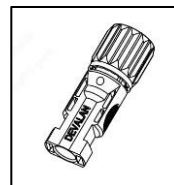

PV negative terminal

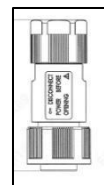

COM Terminal

Figure 5 -1 Options icon

Table 5 -2 List of accessories

N.	Voice	Amount
1	External battery connection terminal (positive)	2 pcs
2	External battery connection terminal (negative)	2 pcs
3	External PV connection terminal (positive)	6 pcs
4	External PV connection terminal (negative)	6 pcs
5	RS485/CAN connector	1 pc

5 .3.4 Tools and parts for installation

The tools and components required for installing the power inverter are as follows. They are not included in the list of supplied and optional components, which must be prepared by the customer or on-site:



Wire stripper



Crimping pliers

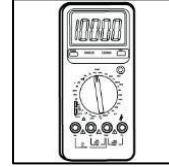

Multimeter

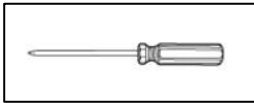

Screwdriver

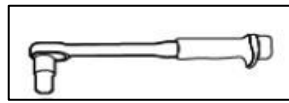

Socket wrench



Replacement screw

Figure 5 -4 Tools

Table 5 -3 List of tools

Instrument	Observation
Wire stripper	1 pc
Crimping pliers	1 pc
Screwdriver	1 set
Compass	1 set
Multimeter	1 set
Internal hex key	1 pc
PV key	1 pc
Screws, nuts, washers	Various

5 .3.5 Installation environment requirements

Before installing the power inverter, check the following environmental requirements:

Table 5 -3 Environmental requirements

Voice	Requirements
Temperature	- 2 0 °C~ 5 0 °C
Humidity	< 9 5 % (non-condensing)

5 .4 Transporting the machine

5 .4.1 Transport instructions

➤Transport the power inverter with packaging as much as possible in order to keep it in a better protective state.



➤When using a forklift or crane for transportation, pay attention to the weight of the power inverter, ensure that the transport vehicle has sufficient load-bearing capacity, and arrange the support or lifting points sensibly.

➤Detailed product parameters and transportation requirements are indicated on the outer packaging. Transportation must be carried out according to the instructions on the packaging. Tables 5 -4 and 5 -5 illustrate the packaging requirements for the PCS:

Table 5 -4 Description of packaging parameters

Name	Description
MODEL	Power inverter model
SIZE	Packaging size
NET WEIGHT	Net weight of PCS
GW	Gross weight of PCS with outer packing box

Table 5 -5 Description of symbols on the packaging

Symbol	Description
	Keep the front side facing up. Do not place the PCS horizontally, tilted, or upside down.
	Handle with care to avoid damage to the power inverter due to excessive shock and friction in the transportation environment.
	Protect from moisture and prevent rain or moisture from affecting the PCS.

5 .5 Positioning and fixing

5 .5.1 Space requirements

- Install indoors/outdoors with good internal ventilation, without excessive humidity or high temperature sources, and without corrosive gases.
- Make sure that the ground wire in the power distribution room is properly grounded and that the ground resistance in a dry environment is less than 4Ω .
- The PCS must be hung on the side of the battery cabinet or on the wall and must have sufficient bearing capacity.
- The inverter must be installed perpendicular to the ground and the inclination angle must be less than 3° .
- Avoid placing it together with flammable and explosive materials and ensure that it complies with fire protection requirements.
- The dimensions of the reserved space are shown in the following figure:

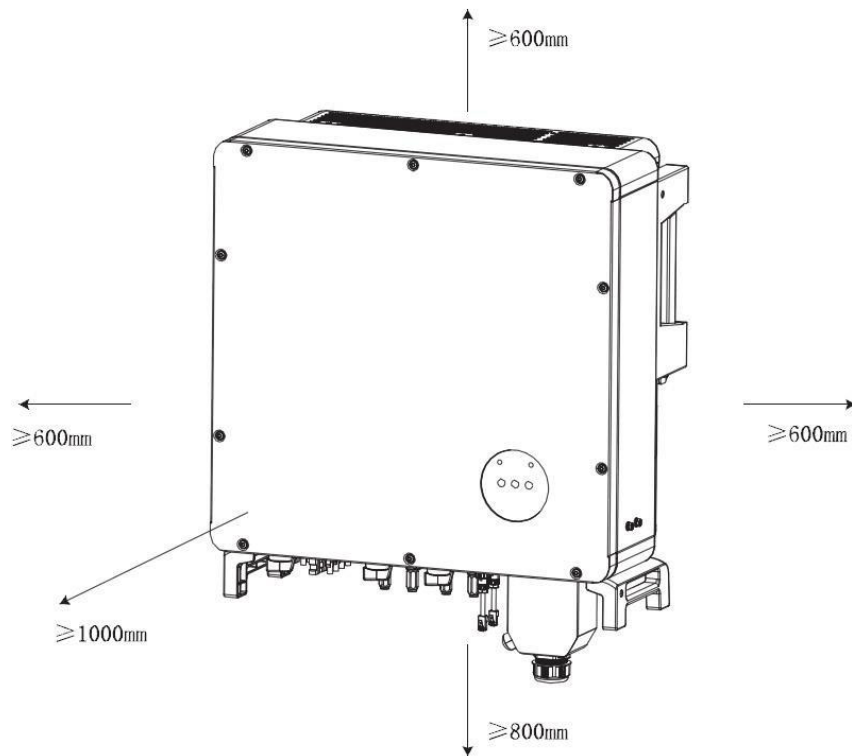

Figure 5 -5 Installation space requirements

5 .5.2 Model dimensions

The mechanical dimensions of the KAC50DP power inverter are shown in the following figure. Users can design and install based on this data.

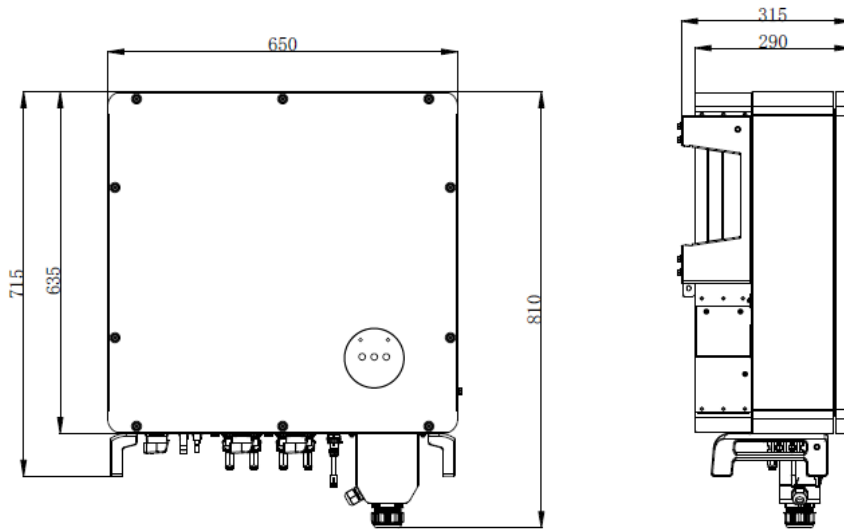

Figure 5 -6 Dimensions of the KAC50DP model

5 .5.3 Suspension installation

The bottom of the KAC50DP power inverter must be securely connected to the bottom of the base. There are mounting holes on the bottom of the power inverter, which are used to secure the system to the steel channel base or the ground. As shown below:

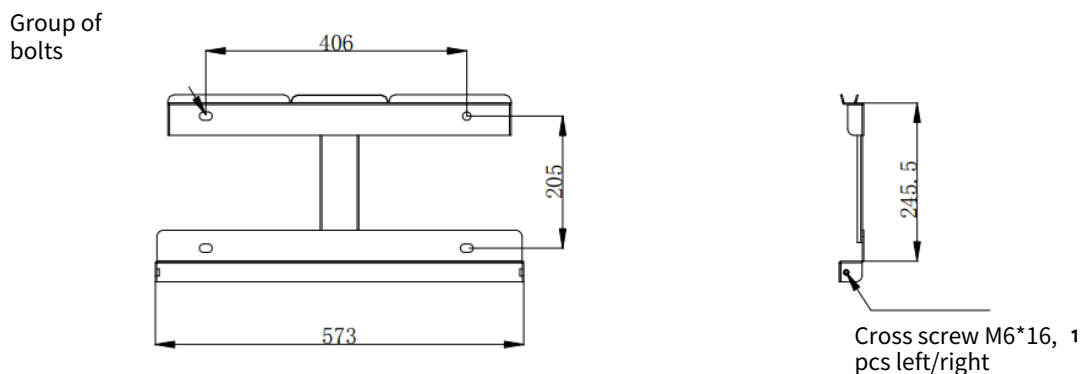

Figure 5 -7 Suspension installation and fixing

5 .6 Air duct design and installation

5 .6.1 Forced ventilation cooling system

The KAC50DP power supply uses forced ventilation for heat dissipation.

5 .6.2 Ventilation environment

To meet the ventilation requirements of the KAC50DP power inverter, the installation environment must meet the following requirements:

- The PCS should not be installed in locations with poor ventilation and low airflow.
- The air inlet must have sufficient space and the air outlet must have sufficient space to discharge the hot air flow.

The schematic diagram of the air inlet and outlet is shown in the figure below.

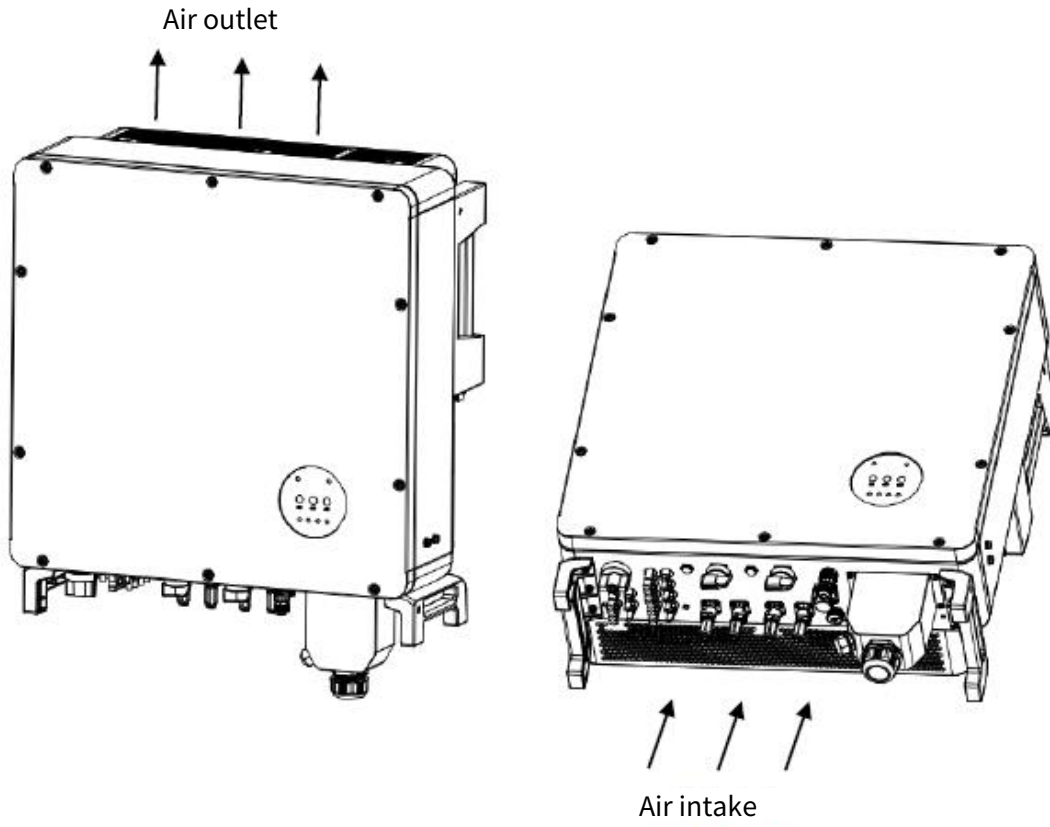

Figure 5 -8 Air inlet and outlet diagram

6

Electrical installation instructions

6.1 Cable requirements

According to the capacity configuration requirements of a single KAC50DP power inverter, it is recommended that the current passing through a 1 mm wire does not exceed 6 A, and the connecting wires on the same side are of the same specification and type. Kstar has provided reference requirements for various interface cables. Users can refer to the following table for cable design. When designing cables, follow the instructions in this section and local wiring regulations, and take environmental conditions into account.

Table 6-1 KAC Power Inverter Power Cable Specifications

Device of connection	Maximum current of a single thread	Wire diameter suggested mm ²	Wire diameter suggested AWG
PV	DC 18 A	4 ~6mm ²	9 ~11AWG
Drums	DC 55 A	10 ~16mm ²	5 ~7 AWG
Three-phase AC	CA 80 A	25 ~35mm ²	2 ~4 AWG
Single-phase AC	CA 18 A	4 ~6mm ²	9 ~11AWG
Ground wire	/	10 ~16mm ²	5 ~7 AWG

※For the three-phase AC external switch, it is recommended to use a switch with rated current ≥ 125 A and rated voltage ≥ 400 VAC.



- The cable sizes shown in this table are for reference only. The actual selection should be based on the cable's operating environment temperature, installation method, heat dissipation conditions, etc.
- Copper cables are recommended; aluminum cables are not supported. Flexible, multi-core cables that are easily bendable are recommended. Single-core or rigid cables that are not easily bendable are not recommended.



WARNING!

Warning

Before proceeding with wiring, make sure that the mains power, PV switches and battery switches are disconnected and post warning signs to prevent others from operating the switches.



WARNING!

Warning

Power cables should be routed in trenches or ducts to avoid mechanical damage to the cables or RF interference to peripheral equipment.

6.2 Wiring specifications

When laying cables, communication wires and power wires must be laid separately. The DC circuit and AC circuit must be laid separately, and the distance between different cables must be greater than 30 mm. When the control cable must cross the power cable, ensure that the angle between the two cables is kept as close to 90° as possible.

The minimum recommended distance between data cables and shielded power cables in parallel is given below.

Table 6-2 Distance between signal cables and power cables

Length of parallel line (m)	Minimum distance (m)
200	0.3
300	0.5
500	1.2

※The data cable should be laid as close as possible to the ground or to supporting cables, such as support beams, steel channels, metal rails, etc.

6.3 Securing and protecting connection cables

6.3.1 Securing the cables

To prevent the copper nose of the wiring harness from loosening under force, causing poor contact or increasing contact resistance and causing heat or even fire, make sure that the screws securing the wiring terminals meet the torque requirements as follows:

The torque values of the screws are as follows:

MCA output terminal:

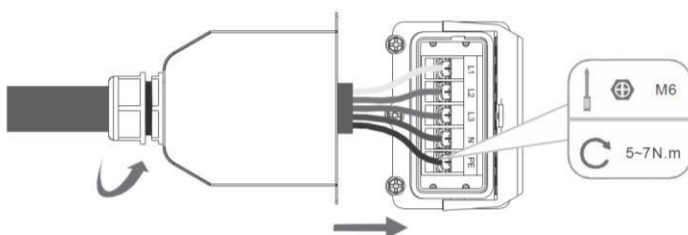

Support Block:

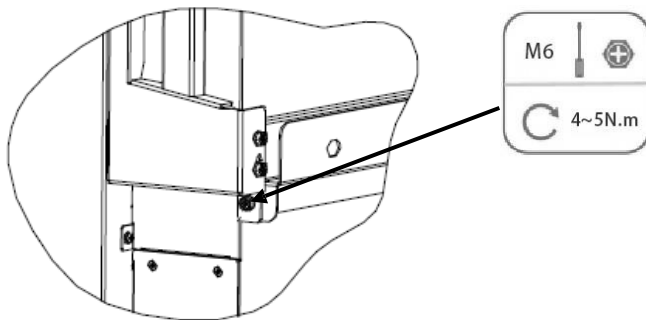
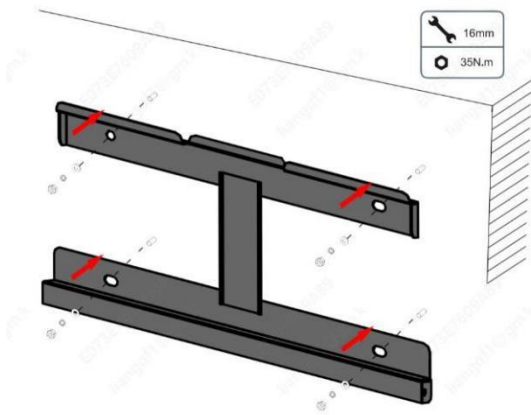

Grounding:

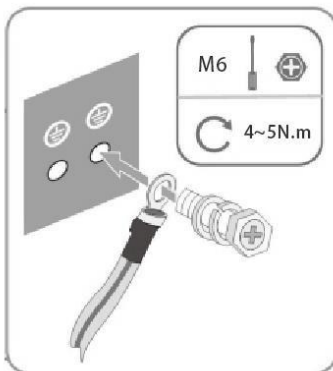

6 .3.2 Cable protection

Cable protection includes communication cables and power cables. The protection methods are as follows:

Communication Cable Protection: Communication cables can easily be torn or fall out of the wiring terminal during construction because they are thin. It is recommended to connect the power circuit first. Try to route them through the cable gland when connecting and secure with cable ties if there is no cable gland. Avoid heating components and cables with strong electric fields when installing.

Power Cable Protection: During installation and connection, avoid scratching or damaging the cable insulation, as this may cause a short circuit. Power cables must also be properly secured.

6.4 DC side wiring

6.4.1 PV side wiring

The DC side wiring correspondence of the PV modules connected to the KAC50DP power inverter is shown in Table 6-4 below.

There are a total of 3 MPPTs, the MPPT voltage range is 350 V~1000V, and the maximum DC current of each MPPT is 36 A. The maximum PV input power of a single KAC50DP power inverter is 75 KW. Please refer to Section 6.5 for the location of the wiring terminals.

Table 6-3

FV+	Connected to the positive terminal of the PV array
FV-	Connected to the negative terminal of the PV array

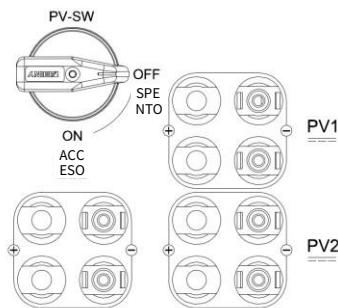

Figure 6-1 PV connection terminal

6.4.2 Battery side wiring

The DC side wiring correspondence of the battery connected to the KAC50DP power inverter is shown in Table 6-5 below.

The battery access voltage is 350 V~750V, and the maximum DC current is 110 A. For a single KAC50DP power inverter, the power must not exceed 1.1 times the rated power. For the location of the wiring ports, see Section 6.5.

Table 6-4

BAT+	Connected to the positive terminal of the battery pack
BAT-	Connected to the negative terminal of the battery pack

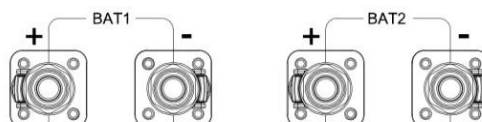

Figure 6-2 Battery connection terminal

6 .4.3 Bus voltage output interface

The KAC50DP is equipped with a bus voltage output interface, which connects to the positive and negative bus inside the machine. The voltage ranges from 350 V to 820 V DC, and 4 A fuses are provided for protection. When the machine is turned on, the interface output voltage can provide auxiliary power for devices such as STS.

PIN	Net	voltage	Electric current
1	The inside is connected to a positive bus bar	350 V~820V DC	Peak 4 A 0.5A for a long time
3	The inside is connected to a negative bus bar		

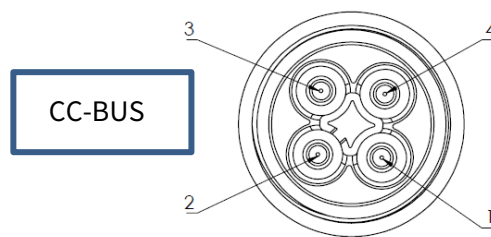

Figure 6 -6 Busbar output

6 .4.4 DC side wiring

The steps are as follows:

Step 1 :Use a multimeter to check whether all terminals of the power inverter have been turned off.

Step 2 :Confirm the positive and negative terminals of the cables and make wire labels.

Step 3 :Connect the positive and negative terminals of the photovoltaic field to the “FV+” and “FV-” terminals.

Step 4 :Connect the positive and negative terminals of the battery pack to the “BAT+” and “BAT-” terminals.



DANGER!

Danger

To avoid personal injury and damage to equipment, power must be turned off before wiring.

- The DC switch is off.
- Use a multimeter to measure that the DC side terminal block is not live.



WARNING!

Warning

DC voltage limited. Make sure the PV voltage does not exceed 1000 VDC! The battery voltage must not exceed 750 VDC!

- Any DC voltage exceeding this limit may cause damage to the power inverter.
- Equipment damage and losses caused in this case are not covered by the warranty.

6 .5 AC side wiring

6 .5.1 AC connection

All KAC50DP power conversion system models are equipped with a grid connection. Only bypass models require a bypass connection. Correspondences are shown in the following tables.

Table 6 -5 Network Connection Matching

AC Terminal	Electricity grid	Cable reference color
L1	Connect to phase A or phase U of the network	yellow
L2	Connect to phase B or phase V of the network	green
L3	Connect to phase C or phase W of the network	red
N	Connect to phase N of the network	Blue or black
PE	Safe grounding	Yellow green roll

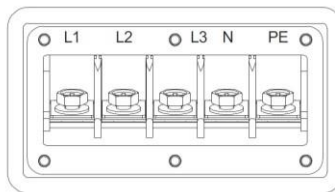
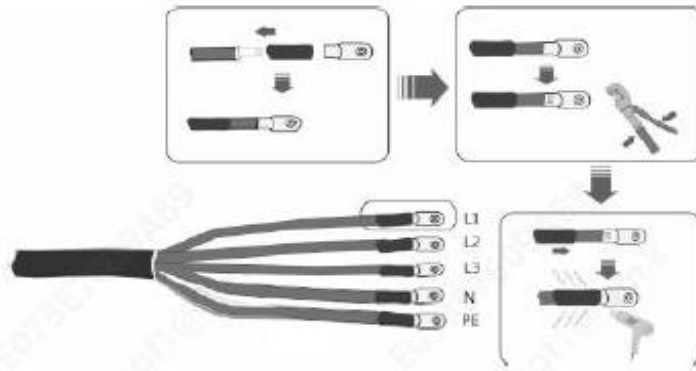

Figure 6 -3 AC connection terminal

Peel off a certain length of protective layer and insulating layer according to the requirements of the diagram.



Making the wires and crimp terminals



Attach the cable to the corresponding terminal

6.5.2 AC side wiring steps:

Step 1 : Use a multimeter to measure and confirm whether all terminals have been turned off.

Step 2 Confirm the phase sequence of the cables and label them. The three-phase AC output cables L1, L2, L3, N, and PE must be supplemented with yellow, green, red, black/blue, and yellow-green cables, respectively, to distinguish the phase sequence.

Step 3 : Correctly connect the ABC (UVW) phases of the grid to the power inverter according to Table 6-6.



- 1 . Recommended circuit breaker model: NDM 3 -160 M/ 3 3 0 0 3 P 1 2 5 A/ 6 9 0 VAC 2 0 KA
- 2 . Recommended leakage protection switch: leakage current 3 0 mA

There's a small waterproof port on the waterproof cover of the AC connection port. This port is used to connect 220 V AC power to air conditioners and other appliances. It can be connected to two- or three-core 5 mm² cables.

AC Terminal	Electricity grid	Tension of line	Observation
L1&L2&L3	Connect to phase A/B/C of the electrical network	220 VAC	The inverter does not supply 220 VAC voltage and can only be powered from the mains.
N	Zero line	0 VAC	
PE	Safety grounding		

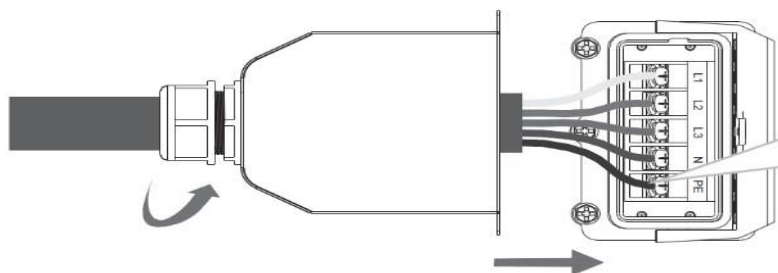

Figure 6-3 220 VAC connection

6 .6 Communication interface

6 .6.1 The KAC50DP has two external communication interfaces, PARA1 and PARA2, used for hand-to-hand communication between two or more PCS when combined. The parallel interface is in parallel, the pin position is the same, and the pinout is shown in the following table:

Table 6 -6 Correspondence of PARA parallel interface connections

PIN	Net
1	RS485_A
2	RS485_A
3	CAN-H
4	CAN-L
5	Zero-crossing synchronization
6	EPO
7	Carrier synchronization
8	GND

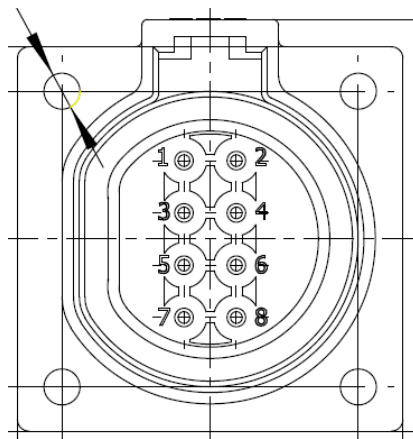

Figure 6 -4 Parallel port connection diagram

6 .6.2 The KAC50DP has a COM communication interface to connect CAN and RS485 communications.



COM port The end of the chassis panel is connected to the right field edge.

COM port field terminal, the pin corresponds to the end of the panel

Figure 6 -5 COM port feet

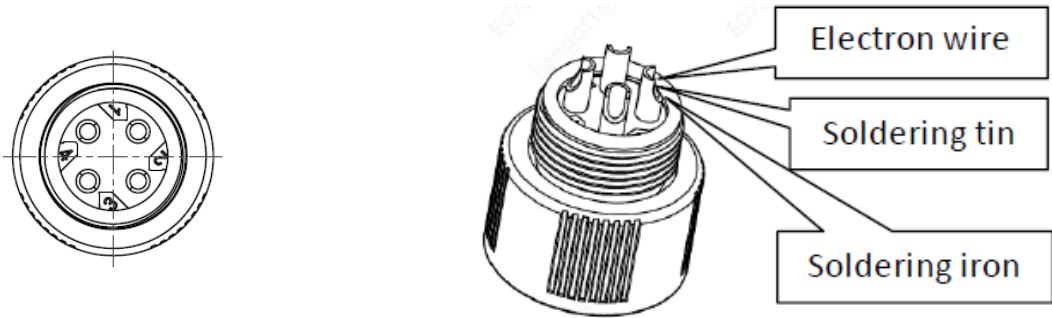

COM terminals also have pin markings

Solder according to the pin instructions; note: they are electric iron and tin are needed

Figure 6 -6 Soldering COM ports

PIN	Net	Link Object 1	Link Object 2
1	CAN-H	Receiving the BMS	/
2	CAN-L	Receiving the BMS	/
3	/	/	/
4	/	/	/

6 .7 Grounding the system

The KAC50DP power inverter enclosure must be reliably grounded. The resistance must not exceed 4 Ω, and the ground wire diameter must not be less than 1.6 mm². Refer to section 6 .5 for internal wiring terminals.

6 .8 Complete installation

Only after all mechanical and electrical installations have been completed and confirmed as correct can you proceed with powering up.

7

Commissioning

7.1 Check before starting

Before commissioning, carefully check the installation of the equipment, especially whether the voltage of the DC and AC terminals meets the requirements of the power inverter and whether the polarity and phase sequence are correct.

Verify that all connections comply with the requirements of the relevant standards and that the system is properly grounded. Grounding resistance is very important for the safety of the entire system. It is necessary to verify that the grounding resistance meets the requirements before initial commissioning.



Attention

Before commissioning, make sure that all switches on the DC and AC side are turned off.

NOTE!

Step 1 : Checking the power inverter

- Before putting the power inverter into operation, a series of checks must be carried out:
- Check that the installation and wiring of the power inverter have been completed according to the contents of Chapter 5 and Chapter 6.
- Check that the AC and DC switches are in the open state.

Step 2 : Checking the voltage on the AC side

- Check whether the three-phase power inverter is correctly connected to the three-phase grid.
- Check whether the phase voltage and line voltage are within the specified range and record the voltage value.
- If possible, measure the total harmonic distortion (THD) of the voltage. If the harmonic distortion is high, the power inverter may not function.

Step 3 : Checking the voltage on the DC side

- The inverter must be connected to the battery pack on the battery side to ensure that the input polarity of each battery pack is correct.
- The inverter must be connected to the PV module on the PV side to ensure that the input polarity of each PV module is correct.



WARNING!

Warning

DC voltage limit. Make sure the PV voltage does not exceed 1 0 0 0 VDC! The battery voltage must not exceed 7 5 0 VDC!

Step 4 : Checking other content

After completing the above inspection, you should carefully check the following items for accuracy.

- All connections have been made according to the contents of Chapter 6 of this manual.
- The switches on the AC side and DC side are disconnected, i.e. in the “OFF” position.



WARNING!

Warning

For power conversion systems with a long downtime, the equipment must be carefully and thoroughly inspected before commissioning to ensure that all indicators meet the requirements.

7 .2 Power On/Off Process

Once all the above elements are met, the PCS can be launched. The operational steps are as follows:

- Step 1** : Close the AC and DC side switches;
- Step 2** : Check whether the configuration information is normal through PC or EMS;
- Step 3** : Issue the boot command via PC or EMS;
- Step 4** : Please note that the green LED light is on and the red LED light is off; if not, please check the error code via PC or EMS.

7 .3 Fault shutdown procedure

7 .3.1 Normal shutdown

During routine maintenance or overhaul, turn off the equipment by following this process:

- Step 1** : Send shutdown command via PC or EMS;
- Step 2** : Disconnect the AC and DC side switches;
- Step 3** : Wait for the bus capacity to discharge and the LED indicator to turn off.



WARNING!

Warning

When the machine is operating normally, it is strictly forbidden to directly disconnect the switches to avoid the risk of electric arcs and damage to the switches.

In severe cases, the PCS may become damaged.

7 .3.2 Shutdown in case of failure or critical moment

When the situation is critical or a failure occurs, follow the procedure below:

Step 1 : The main switch of the upstream AC power grid is off; the main switch of the high-pressure battery brake is off;

Step 2 : Turn off the PV-SW, BAT1-SW and BAT2-SW switches of the inverter.

Step 3 : After confirming that the danger or fault has been removed and that it is necessary to operate, switch the above switch.

8

Maintenance and troubleshooting

8 .1 Description

Due to the influence of ambient temperature, humidity, dust and vibration, the internal components of the power inverter age, compromising the system performance and even causing malfunctions.

Therefore, it is necessary to perform daily and regular maintenance on the power inverter to ensure its normal operation and longevity. All measures and methods that help the inverter maintain good operating condition are part of maintenance.

If a malfunction cannot be solved with the help of this manual, please contact Shenzhen Kstar New Energy Co., Ltd. and provide the following information, so that we can provide better service:

- Photo of the fault location.
- Model and serial number of the power inverter.
- Information about the components connected to the power inverter, the configuration of the energy storage battery, and the grid parameters.
- Power inverter communication connection diagram.
- Fault information and brief description.

8 .2 Precautions

8 .2.1 General safety regulations

To ensure operator safety during maintenance or overhaul of the power inverter, the following five safety rules must be observed:

- Disconnect the external power supply of the power inverter.
- Make sure that the power inverter is not accidentally powered on.
- Use a multimeter to ensure that the inside of the power inverter is completely free of voltage.
- Make sure the power inverter is properly grounded.
- For any live parts near the operating part, use insulating material for covering.



WARNING!

Warning

Only qualified and authorized personnel may perform maintenance and other operations on the power inverter.

During maintenance work, do not leave screws, washers and other metal parts in the power inverter to avoid damaging the system!



WARNING!

Warning

If only the switch is disconnected, the cable connection terminals inside the power inverter are still live!

Before opening the machine cover and starting formal maintenance work, it is necessary to disconnect not only the switch, but also the front and rear switches of the power inverter.



WARNING!

Warning

After the power inverter goes out of operation, wait at least 10 minutes before operating.

8.2.2 Work and maintenance cycle

Table 8 -1 List of maintenance items

Voices of maintenance	Maintenance content	Period advised
Keep the registers	<ul style="list-style-type: none"> ◆Export and backup data with USB. 	1 month
Inspection of the PCS	<ul style="list-style-type: none"> ◆Observe whether the power inverter is damaged, deformed or rusted. ◆Listen for any abnormal sounds during operation of the power inverter. ◆Observe the parameters during operation through the background. ◆Use a thermal imaging camera to check for system heating. ◆Check whether the ventilation, ambient temperature, humidity, dust and other environments around the power inverter meet the requirements. 	Half a year
Cleaning the duct of the air	<ul style="list-style-type: none"> ◆Check the dust in the air duct and clean it if it is serious. ◆Check for abnormal vibrations when the fan is running. 	Half a year
Function of safety	<ul style="list-style-type: none"> ◆Check if the system EPO button is invalid. ◆Check if the switch is invalid. 	Half a year
Connection of the circuit	<ul style="list-style-type: none"> ◆Check for loose electrical connections or poor contact. ◆Check that all cables and metal contact surfaces are not damaged or scratched. ◆Check if the insulating tape on a wiring terminal is peeling off. ◆Check if the position of the screws is overheated. 	1 year

Inspection of the symbols	<ul style="list-style-type: none"> ◆ Check the warning signs on the machine body and the symbols on other equipment, ◆ If a symbol is blurred or damaged, replace it promptly. 	1 year
---------------------------	--	--------



The table shows only the recommended routine maintenance cycles for the products. The actual maintenance cycle should be determined based on the specific installation environment of the product. Factors such as the size of the power plant, its location, and the site environment affect the maintenance cycle. If the operating environment is sandy or dusty, the maintenance cycle should be reduced and its frequency increased.

8 .2.3 Replacing components

- Component replacement must be done by professionals.
- When replacing electrical components on your power inverter, be sure to use components from the same manufacturer and model! The component model can be found on the inverter or product label. If you cannot find it, please contact Shenzhen Kstar New Energy Co., Ltd.
- If you need to replace products from other manufacturers or different models from the same manufacturer, Kstar must analyze and confirm this in advance, otherwise Kstar will not be responsible for any accidents or property losses that may arise as a result.

8 .3 Troubleshooting

8 .3.1 Troubleshooting



WARNING!

Warning

In a fault condition, lethal high voltages may still be present inside the power inverter! Only qualified technicians may perform the operations described in this chapter. "Qualified" means that the operator has received professional training in equipment troubleshooting during the initial phase. Perform only the troubleshooting operations described in this manual. Observe all safety regulations during operation.

When the power inverter fails to produce as expected or the charge and discharge capacity changes abnormally, please pay attention to the following items:

- The open circuit voltage of the energy storage battery
- If the machine is in a faulty state
- If the power grid is connected and powered correctly
- Check whether the equipment communication is normal

8 .3.2 Failure without alarm

The machine makes a loud noise

Check whether the power supply is within the normal range; measure whether the current and voltage waveform connected to the mains are normal; check and replace the cooling fan.

Serial communication mode:

Check if all wiring is in good condition and if phases A/B are connected reversely.

The communications adapter is not compatible; replace the adapter and try again. Check whether the local address and transmission speed are compatible with your PC.

8 .3.3 Fault with alarm

The color of the LED indicator displays the alarm and fault items (green light: operation; yellow light: alarm; red light: fault), and the corresponding solutions are shown in Table 8 -2:

Table 8 -2 Alarm Fault Handling Methods

Type of fault	Treatment method
Low battery voltage	Disconnect the DC switch and check the DC side voltage and energy storage battery configuration
High battery voltage	Disconnect the DC switch and check the DC side voltage and energy storage battery configuration
Connection fault battery reverse	Disconnect the DC switch and check the positive and negative wiring of the energy storage battery
Battery hardware overcurrent	Turn off, check whether the inverter input and output are overloaded or short circuited.
Connection failure inverse of PV	Disconnect the switch on the PV side and check the positive and negative wiring on the PV side
High voltage PV failure	Disconnect the PV side switch and check the PV side voltage configuration
PV hardware overcurrent	Turn off, check whether the input on the PV side is overloaded or short-circuited
High mains overvoltage	Turn off and check the voltage at the connection point
Low mains voltage	Turn off and check the voltage at the connection point
Phase reversal of the mains voltage	Disconnect the mains power switch, turn off and check the three-phase wiring
Abnormal network frequency	Turn off and check the mains voltage
Output relay failure	Turn off and check if the AC relay is damaged.
PCS Overcurrent	Power off, check whether the PCS input and output are short circuited or the PCS is overloaded.
PCS current limiting wave by wave	Power off, check whether the PCS input and output are short circuited or the PCS is overloaded.
PCS Overtemperature	Turn off the power, check if the PC fan is faulty and if the air duct is not blocked.

PCS out of sync	Turn off, check the PCS settings and verify that the parallel cable is connected normally
Lightning protection failure	Turn off and check the PCS lightning protection
BMS communication failure	Power off, check if the communication cable between the PCS and the battery system is loose
EPO failure	Turn off, check if the EPO button is pressed

8 .3.4 Protection function

The power inverter is equipped with comprehensive protection and warning functions. If there are any anomalies in the input voltage or the power grid, it can be effectively activated to ensure the safe operation of the power inverter and continue to operate in the set mode once the anomaly has disappeared.

Table 8 -3 PCS Alarm and Protection Functions

Function	Description
Protection from DC overvoltage/ undervoltage	When the DC voltage of the energy storage battery exceeds the allowable voltage range, the power inverter stops working and displays the fault type on the PC or EMS. The power inverter can quickly detect abnormal voltage and react.
Protection from network overvoltage/ undervoltage	When the power inverter detects that the grid voltage exceeds the permissible voltage range, it stops working and displays the fault type on the PC or EMS. The power inverter can quickly detect and respond to abnormal voltages.
Protection from grid over/undervoltage	When the power inverter detects that the grid frequency fluctuations exceed the permissible range, it stops working, sends a warning signal, and displays the fault type on the PC or EMS. The power inverter can quickly detect and respond to abnormal frequencies.
Island protection	When the power inverter detects that the grid voltage is 0 , it stops working and displays the fault type on the PC or EMS. The power inverter can quickly detect the abnormal voltage and react.
AC Overcurrent Protection	When the output power of the energy storage battery exceeds the maximum allowable DC input power, the power inverter limits the current and operates at the maximum allowable AC output power. When it detects that the AC current exceeds 1 .1 times the rated current, the power inverter stops working. After returning to normal, the power inverter should be able to operate normally.

AC leakage current protection	The power inverter has a ground fault protection function, and the power cable is equipped with a leakage current sensor. When the leakage current exceeds 2 A, the machine stops immediately. When the current is less than 1.5 A, the protection can be eliminated. The fault is displayed on the PC or EMS.
Protection from IGBT overtemperature	The power inverter's IGBT module uses a high-precision temperature sensor, which can monitor the IGBT module temperature in real time. When the temperature is too high, the DSP issues a command to shut down the power inverter to ensure stable operation of the equipment.
Protection from overtemperature environmental	The power inverter uses a high-precision temperature sensor to monitor the temperature inside the machine in real time. When the temperature is too high, the DSP issues a command to shut down the power inverter to ensure stable operation of the equipment.
DC overcurrent protection	When the power inverter detects that the DC current exceeds 1.2 times the rated current, it stops working, sends a warning signal, and displays the fault type on the LCD. After returning to normal, the power inverter should be able to operate normally.
Phase reversal protection	When the power inverter detects that the three-phase voltage of the connected power grid is incorrect during self-inspection, it sends a warning signal and displays the fault type on the LCD. After returning to normal, the power inverter must be restarted and pass the self-test before it can operate normally.
AC voltage unbalance protection	When the power inverter detects that the difference between the three-phase AC voltages exceeds the allowable range, it stops working and displays the fault type on the PC or EMS. The power inverter can quickly detect the abnormal voltage and respond.
Fan failure protection	The power inverter fan is equipped with an automatic detection function. When it detects that the fan is not running, it can quickly send fault information to the DSP. The DSP will issue a command to stop the power inverter, simultaneously sending a warning signal and displaying the fault type on the PC or EMS.
AC relay failure protection	When the power inverter is in standby, on-grid or off-grid state and detects that the AC relay is disconnected, it stops working, sends out a warning signal and displays the fault type on the PC or EMS.

Appendix 1 : Technical parameters

Model	KAC50DP
PV Input Parameters	
Maximum input voltage	1,000 VDC
MPPT Voltage Range	350 ~800 VDC
MPPT voltage range (full load)	667 VDC
Maximum continuous photovoltaic input power	7.5 kW
Number of MPPTs	3
Maximum PV short circuit current	36 A
Maximum short circuit current for MPPT	2
Battery input parameters	
Battery Type	Lithium-ion battery
Battery voltage range	350 ~750 VDC
Rated voltage	512 VDC
Maximum charging current	110 A DC
Maximum battery input channels	2
Output parameters (AC, on-grid)	
Maximum active input power	50 kW
Maximum AC power	55 kVA
Rated AC current	72 A
Maximum continuous input current	80 A
Rated AC voltage	230 /400 VAC; 3 /N/PE
AC voltage range	340 ~440 VAC
Nominal network frequency	50 /60 Hz
AC voltage frequency range	45 ~55 Hz/ 55 ~65 Hz
Total Harmonic Distortion (THD)	<3% (rated power)

Power factor	> 0.99 (nominal power)
Power factor adjustment range	1 (early) ~ 1 (late)
Output parameters (AC, off-grid)	
Maximum active input power	5.0 kW
Rated AC current	7.2 A
Rated AC voltage	230/400 VAC; 3/N/PE
Nominal network frequency	50/60 Hz
Power factor	> 0.99 (nominal power)
Efficiency	
Maximum efficiency	97.50%
Protection	
DC switch	Yes
DC reverse polarity protection	Yes
Isolation impedance detection	Yes
Surge protection	Yes
Island protection	Yes
Monitoring the electricity grid	Yes
AC Leakage Current Detection	Yes
General parameters	
Dimensions (W x H x D)	650 x 715 x 325 mm
Weight	7.5 kg
Isolation mode	Non-insulated type
Degree of protection	IP65
Oversvoltage level (DC)	OVC II
Oversvoltage Level (AC)	OVC III
Operating temperature range	-25°C~+60°C (derating at 45°C)
Relative humidity (non-condensing)	0~100%

Cooling mode	Intelligent air cooling
Maximum working altitude	3,000 m
Display	LED
Communication interface	CAN/RS485

Appendix 2 : Quality Assurance

For products that fail during the warranty period, Shenzhen Kstar New Energy Co., Ltd. will repair or replace them with new ones free of charge.

1 . Test

During the warranty period, the customer must present the invoice and purchase date of the product. The branding on the product must also be clearly visible, otherwise the warranty will be void.

2 . Warranty conditions

- Non-compliant products after replacement will be handled by Kstar.
- The customer must allow reasonable time for Kstar to repair the non-functioning equipment.

3 . Disclaimer

The following situations are not covered by the warranty:

- The free warranty period for the machine and parts has expired.
- Transport damage.
- Improper installation, modification or use.
- Operation in harsh environments beyond those described in this manual.
- Failure or damage to the machine caused by installation, repair, modification or disassembly by service personnel other than our company.
- Installation and use outside the regulations of relevant international standards.
- Failures or damage caused by non-standard or non-Kstar components or software.
- For damage caused by abnormal natural environment, Kstar can provide paid maintenance services.



Kstar products and product manuals are constantly being improved and updated to ensure customer satisfaction. If there is a difference between the manual and your product, please refer to the specific product. If you have any further questions, please contact Kstar.

Appendix 3 : Terminological interpretation

Terminological definition

ATS ————— Automatic Transfer Switch

STS ————— Static Transfer Switch

AC ————— Alternating Current

DC ————— Direct current

BESS ————— Battery Energy Storage System

ESS ————— Energy Storage System

EMS ————— Energy Management System

BMS ————— Battery Management System (inverter)

PCS ————— Power Inverter

SLD ————— Single Line Diagram

SOH ————— (battery) health, expressed as a percentage

SCR ————— Thyristor rectifier

DOD ————— Depth of discharge, residual battery capacity, expressed as a percentage

EOD ————— End of download

SOC ————— State of charge (of a battery)

UI ————— User Interface

EPO ————— Emergency Power Off

SOD ————— Surge Protection

KSTAR

Shenzhen Kstar New Energy Co., Ltd.

Address: Kstar Industrial Park, No. 7 Road, West District, High-tech Park, Guangming New District, Shenzhen

ZIP Code: 5 1 8 1 0 6

After-sales service toll-free number: 4 0 0 -700-9662

Website: www.kstar.com.cn

Email: service@kstar.com.cn

※Product dimensions and parameters are subject to change without notice.