

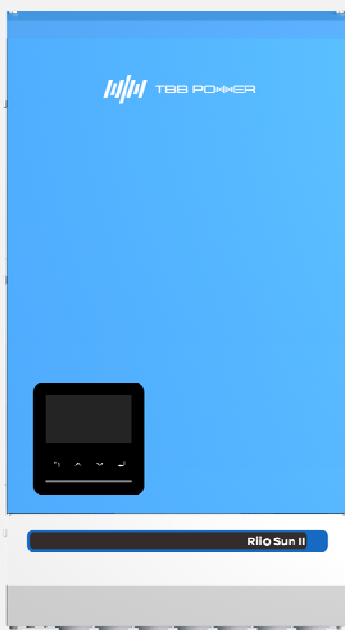

All In One Solar Inverter

USER MANUAL

RiiO Sun II Series



Revision History

Version	Description
A1.0	Initial Version Hardware Ver V2.0, Firmware Ver V1.00, Software Ver V1.00
A1.1	Hardware Ver V2.0, Firmware Ver V1.04, Software Ver V1.05
	2.2.2 Connection Terminal “ComSYS”: delete ES100
	2.2.2 Connection Terminal “ComMON Port Pin Definition”: Definition Change for Pin 4 and Pin 5
	Add relevant information for RiiO Sun II 8kVA-S
	Add 2.3.2 Parallel and Three-phase
	5.Operation: Operation-related software upgrade and content adjustment
A2.0	Hardware Ver V2.0, Firmware Ver V1.05, Software Ver V1.06
	Appearance version upgraded to V2.0 (The RiiO Sun II Appearance version in User Manual version A1.0 and A1.1 is V1.0)
	Com Port version upgraded to V2.0 (The RiiO Sun II Com Port version in User Manual version A1.0 and A1.1 is V1.0)
	Add relevant information for RiiO Sun II 2KVA-S-LV, 2KVA-M-LV, 3KVA-S-LV, 3KVA-M-LV, 4KVA-S-LV
	5.Operation: Operation-related software upgrade and content adjustment

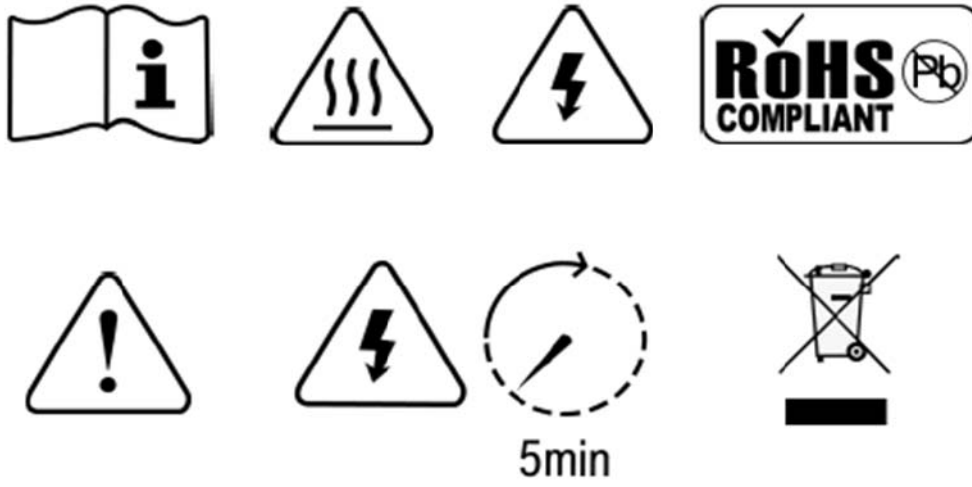

WARNING: HIGH VOLTAGE INSIDE

CAUTION: THE DC FUSE MUST HAVE BEEN TURNED OFF BEFORE SERVICING

MADE IN CHINA

Disclaimer

Unless specially agreed in writing, TBB Renewable (Xiamen) Co., Ltd.

- Takes no warranty as to the accuracy, sufficiency of suitability of any technical or other information provided in this manual or other documentation.
- Assumes no responsibility or liability for loss or damage, whether direct, indirect, consequential or incidental, which might arise out of the use of such information.
- Offers standard warranty with its products, taking no responsibility for direct or indirect loss due to equipment failure.

About This Manual

This manual describes our product features and provides procedure of installations. This manual is for anyone intending to install our equipment.

General Instruction

Thanks for choosing our products and this manual is suitable for RiiO Sun II. This chapter contains important safety and operation instructions. Read and keep this User Guide well for later reference.

RiiO Sun II needs to be installed by professionals and please pay attention to the following points prior to installation:

Please make sure the input voltage or voltage of battery is equal to the nominal input voltage of this inverter.

- Please connect the positive terminal “+” of the battery to the “+” input of the inverter.
- Please connect the negative terminal “-” of the battery to the “-” input of the inverter.
- Please use the shortest cable for connection and ensure a secure connection.
- While connecting, please secure the connection and avoid the short circuit between the positive terminal and the negative terminal of the battery, to protect the battery from damage.
- The inverter has high voltage inside. Only the authorized electrician can open the case.
- The inverter is NOT designed to be used in any life-sustaining equipment.

Contents

1. General Safety Instruction	1
1.1 Safety Instruction.....	1
1.2 General Precaution	1
1.3 Precaution regarding Battery Operation.....	1
2. Instruction	2
2.1 Brief Instruction	2
2.1.1 General Description	2
2.1.2 Naming Rules	3
2.2 Structure.....	3
2.2.1 Front.....	3
2.2.2 Connection Terminal	4
2.2.3 Dimension	8
2.3 Function.....	10
2.3.1 Power Control and Power Assist.....	10
2.3.2 Parallel and Three-phase.....	10
2.3.3 Work without Battery Mode	10
2.3.4 Auto Restart While AC is Recovering.....	10
2.3.5 Auto Restart While PV is Recovering.....	10
2.3.6 Powerful and Reliable Inverter	11
2.3.7 Professional Battery Charger	11
2.3.8 Transfer.....	14
2.3.9 Feeding energy back into the grid.....	14
2.3.10 Protection Function	15
2.3.11 Communication	15
2.3.12 ECO Mode.....	15
2.3.13 Maximum Power Point Tracking.....	16
2.3.14 Comprehensive Protection	16
3. Installation and Wiring	17
3.1 Pre-installation Inspection	17
3.1.1 Check Outer Packing	17
3.2 Select Installation Location.....	17
3.2.1 Requirement	17
3.2.2 Installation Space Requirements	18
3.3 Installation	18
3.4 Preparation Before Wiring	20
3.4.1 PV Array Preparation	20
3.4.2 Breaker Preparation.....	20
3.4.3 Cable Preparation	22
3.5 Wiring	23
4. Configuration	26
4.1 Check Before Operation	26
4.2 Power ON Test.....	26
4.3 Power OFF	26
5. Operation	27
5.1 Operation and Display Panel.....	27

5.2	Polling Interface on the Main Page.....	28
5.3	Quick Query Interface.....	32
5.4	Fault/Warning Code Query Interface	32
5.5	Setting Interface	33
5.5.1	Instructions on Item Settings.....	34
5.5.2	Parameter Code.....	35
6.	FAQ	41
6.1	Fault Code.....	41
6.2	Warning code	42
7.	Specification.....	45

1. General Safety Instruction

1.1 Safety Instruction

As dangerous voltage and high temperature exist within the RiiO Sun II all-in-one solar inverter, only qualified and authorized maintenance personnel are permitted to open and repair it.

This manual contains information concerning the installation and operation of the RiiO Sun II all-in-one solar inverter. All relevant parts of the manual should be read prior to commencing the installation. Please follow the local regulations meantime.

Any operation against safety requirement or against design, manufacture, safety standard are out of the manufacturer warranty.

1.2 General Precaution

- Do not expose to rain, snow or liquids of any type. It is designed for indoor use.
- To avoid fire and electric shock, make sure all cables are selected with right gauge and connected well. Cables with smaller or broken cables are not allowed to use.
- Please do not put any inflammable goods next to the RiiO Sun II.
- Never place the RiiO Sun II directly above batteries. Gas from a battery will corrode and damage the RiiO Sun II all-in-one solar inverter.
- Do not place battery over the RiiO Sun II.

1.3 Precaution regarding Battery Operation

- Use plenty of fresh water to clean in case battery acid contacts skin, clothing, or eyes and consult with a doctor as soon as possible.
- The battery may generate flammable gas during charging. Never smoke or allow a spark or flame in vicinity of a battery.
- Do not put the metal tool on the battery. Spark and short circuit might lead to explosion
- Remove all personal metal items such as rings, bracelets, necklaces, and watches while working with batteries. Batteries can cause short-circuit current high enough to melt metal, and could cause severe burns.

2. Instruction

2.1 Brief Instruction

2.1.1 General Description

RiiO Sun II series all-in-one solar inverter (hereinafter referred to as RiiO Sun II) is a low-frequency transformer-based inverter integrated with multiple functions like battery inverter, AC charger, and MPPT charger, suitable for backup power and off-grid applications.

RiiO Sun II series has the following features:

1. Strong surge capability to carry various inductive loads, such as air conditioners, refrigerators, water pumps, etc.
2. 5KVA and 6KVA models are built-in with two independent MPPT trackers respectively. Two PV arrays can be mounted on two different sides of a sloped roof to optimize the installation and improve the use of solar energy.
3. Flexible configuration on energy priority to charge the battery or power the loads with grid or solar energy, meeting the needs of different application scenarios.
4. Intelligent DC Coupled PV system to maximize the use of solar energy.
5. Models rated at 5KVA and more are designed with a Smart Port, which can be programmed as AC OUT2 or a generator input port.
6. Support powering loads with AC bypass or PV energy when working without the battery, saving investment in battery at the initial stage of the system.
7. Equipped with Power Assist function to relieve power supply pressure of AC side under short-term overload condition.
8. Equipped with Bypass Assist function to relieve power supply pressure of battery side under short-term overload condition and limit the battery's discharge power, effectively limiting the discharge current of the lithium battery BMS, thus to avoid overcurrent protection of the BMS.
9. Intelligent fan control to minimize noise.
10. Human-machine interface visualization design: 3.2-inch color screen + LED indicators + Button + buzzer.

Note: The LED indicators for the Appearance version V1.0 consist of three circular monochrome indicators, and the buttons are mechanical. For the Appearance version V2.0, there is a multicolored indicator strip, and the buttons are touch-sensitive.

11. Flexible in system expansion, the RiiO Sun II supports establishment of a parallel or three-phase system with the usage of a parallel module RiiO Mate (Com Port version V1.0) or by just connecting the cables to the ComSync In/Out Com Ports of the inverters (Com Port version V2.0).

2.1.2 Naming Rules

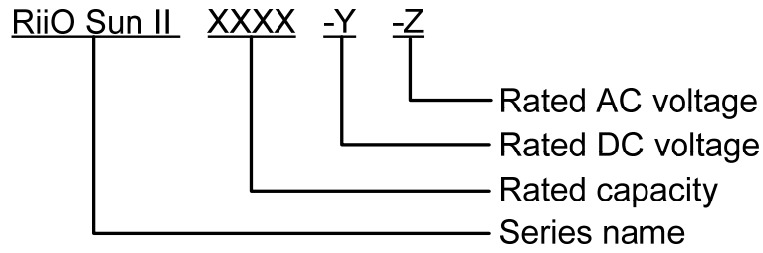

Figure	Explanation	
RiiO Sun II	Series name	
2KVA	Indication of rated power	2000W
3KVA		3000W
4KVA		4000W
5KVA		5000W
6KVA		6000W
8KVA		8000W
-M	Indication of rated DC voltage	24VDC
-S		48VDC
--	Indication of rated AC voltage	230VAC
-LV		120Vac

2.2 Structure

2.2.1 Front

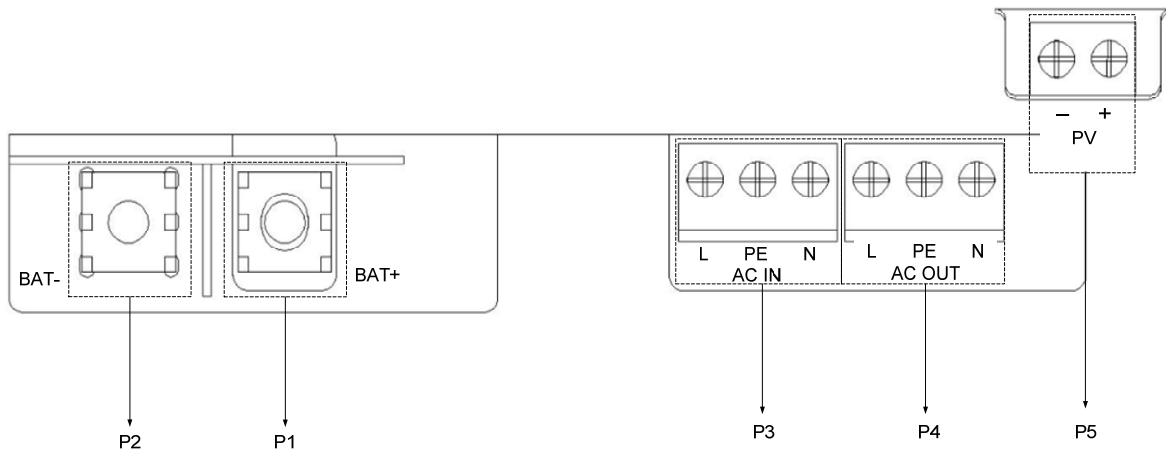
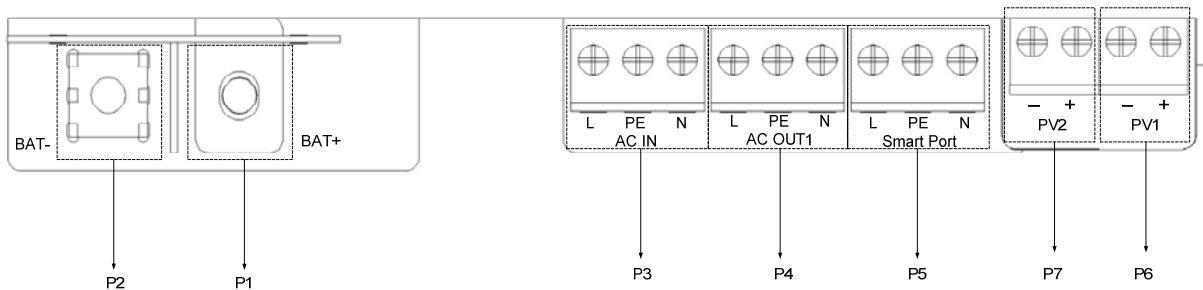

Figure 2-1 RiiO Sun II structure in front view

2.2.2 Connection Terminal

2KVA-M, 3KVA-M, 3KVA-S, 4KVA-S, 2KVA-S-LV, 2KVA-M-LV, 3KVA-M-LV, 3KVA-S-LV, 4KVA-S-LV
Power Port

No.	Name	Description	Note
P1	BAT+	Battery Positive Input	M8 bolt
P2	BAT-	Battery Negative Input	
P3	AC IN	AC Input	ERTB10 terminal
P4	AC OUT	AC Output	ERTB10 terminal
P5	PV1	PV Input 1	ERTB10 terminal





5KVA-S, 6KVA-S, 8KVA-S
Power Port

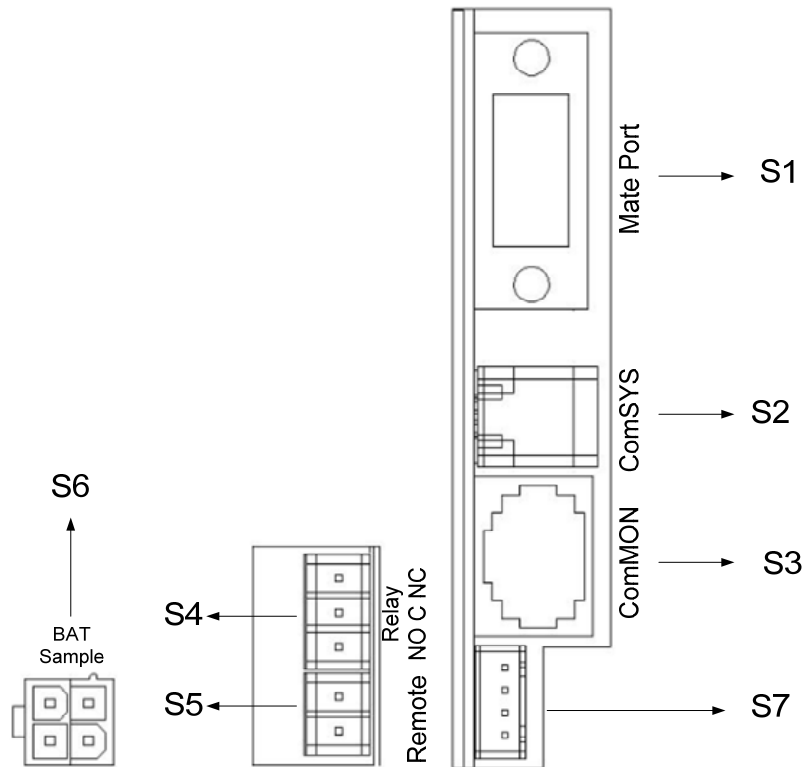

No.	Name	Description	Note
P1	BAT+	Battery Positive Input	M8 bolt
P2	BAT-	Battery Negative Input	
P3	AC IN	AC Input	ERTB10 terminal
P4	AC OUT1	AC Output 1	ERTB10 terminal
P5	Smart Port	Smart Port for AC Output 2 or Generator AC Input	ERTB10 terminal
P6	PV1	PV Input 1	ERTB10 terminal
P7	PV2	PV Input 2	ERTB10 terminal





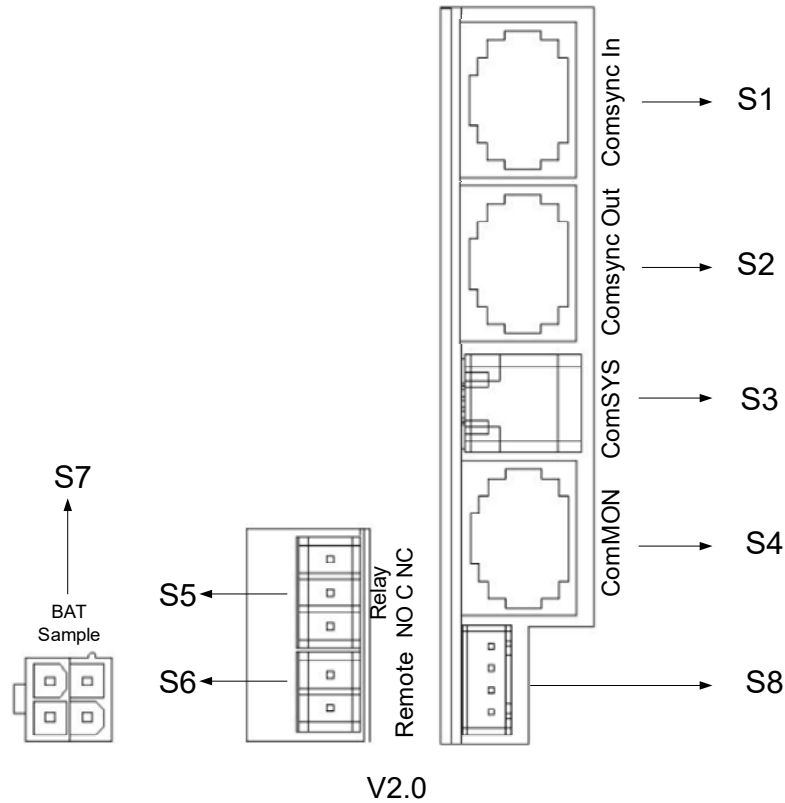

V1.0

No.	Name	Description	Note
S1	Mate Port	RiiO Li is a module for CAN communication with the lithium battery. RiiO Li is a standard accessory of RiiO Sun II. RiiO Mate is a module for CAN communication among multiple units in parallel and for CAN communication with the lithium battery. RiiO Mate is an optional accessory of RiiO Sun II.	
S2	ComSYS	System communication port for connecting to the Solar Mate, Meter, etc.	
S3	ComMON	Monitoring communication port for connecting to the upper computer (via TBB Interface), Kinergy II, E4, Ether-Link, etc.	 Connecting to undefined port is prohibited for it could lead to inverter damage.
S4	Relay	Dry output contact. Its control logic can be selected through the TBB Link.	Built-in 30Vdc/3A or 250Vac/3A relay
S5	Remote	Remote on/off control	 Only for connecting to a touch switch. It is forbidden to connect to voltage signals.
S6	BAT Sample	Battery temperature sampling	







No.	Name	Description	Note
S1	ComSync In	1. For multiple inverters running in parallel system or three-phase system. 2. For connecting lithium battery BMS communication.	
S2	ComSync Out	1. For multiple inverters running in parallel system or three-phase system.	
S3	ComSYS	System communication port for connecting to the Solar Mate, Meter, etc.	
S4	ComMON	Monitoring communication port for connecting to the upper computer (via TBB Interface), Kinergy II, E4, Ether-Link, etc.	 Connecting to undefined port is prohibited for it could lead to inverter damage.
S5	Relay	Dry output contact. Its control logic can be selected through the TBB Link.	Built-in 30Vdc/3A or 250Vac/3A relay
S6	Remote	Remote on/off control	 Only for connecting to a touch switch. It is forbidden to connect to voltage signals.
S7	BAT Sample	Battery temperature sampling	

ComSync In Port Pin Definition (V2.0)

Pin No.	Definition
1	 For internal use, pins of ports connected to external devices must be suspended
2	 For internal use, pins of ports connected to external devices must be suspended
3	RS485_A
4	CAN_H
5	CAN_L
6	RS485_B
7	 For internal use, pins of ports connected to external devices must be suspended
8	 For internal use, pins of ports connected to external devices must be suspended

ComSync Out Port Pin Definition (V2.0)

Pin No.	Definition
1	 For internal use, pins of ports connected to external devices must be suspended
2	 For internal use, pins of ports connected to external devices must be suspended
3	RS485_A
4	CAN_H
5	CAN_L
6	RS485_B
7	 For internal use, pins of ports connected to external devices must be suspended
8	 For internal use, pins of ports connected to external devices must be suspended

ComMON Port Pin Definition

Pin No.	Definition
1	Remote+
2	Remote-
3	RS485_A
4	--
5	--
6	RS485_B
7	+12V (10-14V/400mA)
8	0V

ComSYS Port Pin Definition

Pin No.	Definition
1	NC
2	RS485_A
3	RS485_B
4	NC

BAT Sample Port Pin Definition

Pin No.	Definition
1	NC
2	NC
3	Battery temperature sampling+
4	Battery temperature sampling-

2.2.3 Dimension

Note: The dimensions are the same for both the V1.0 and V2.0 Appearance versions.

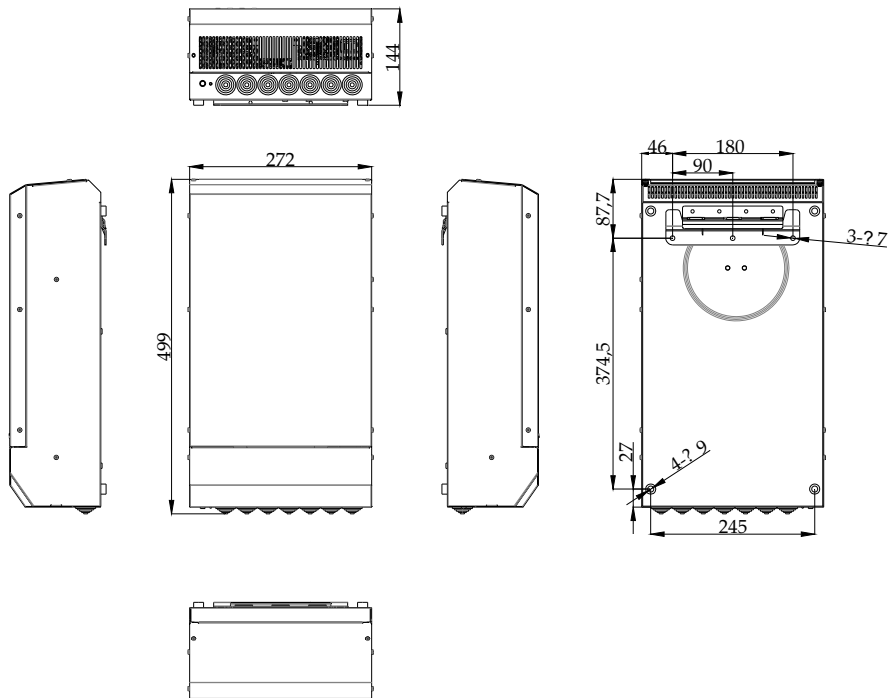

2KVA-M, 3KVA-M, 3KVA-S, 4KVA-S, 2KVA-S-LV, 2KVA-M-LV, 3KVA-M-LV, 3KVA-S-LV, 4KVA-S-LV

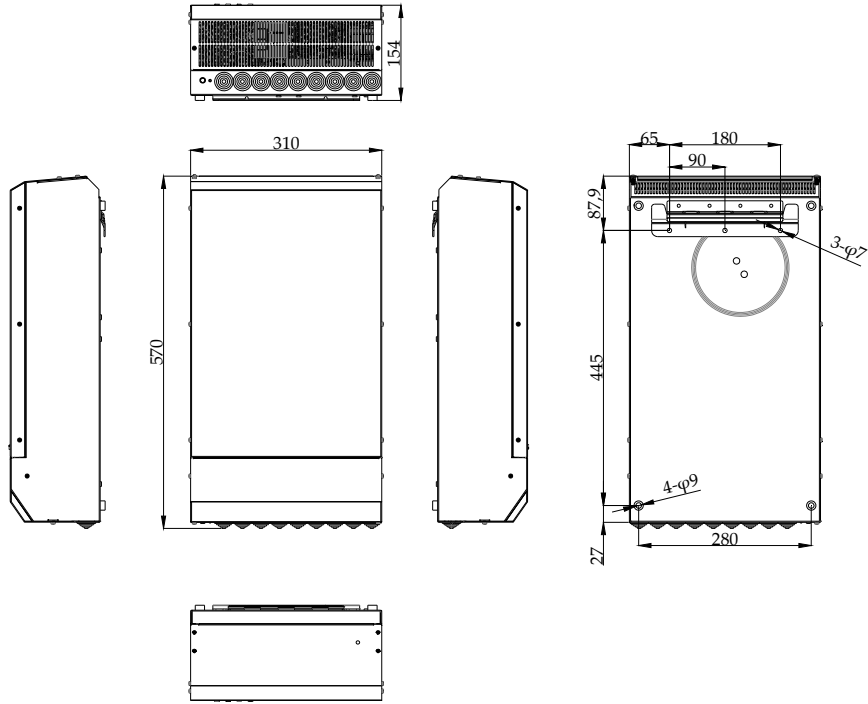

5KVA-S, 6KVA-S

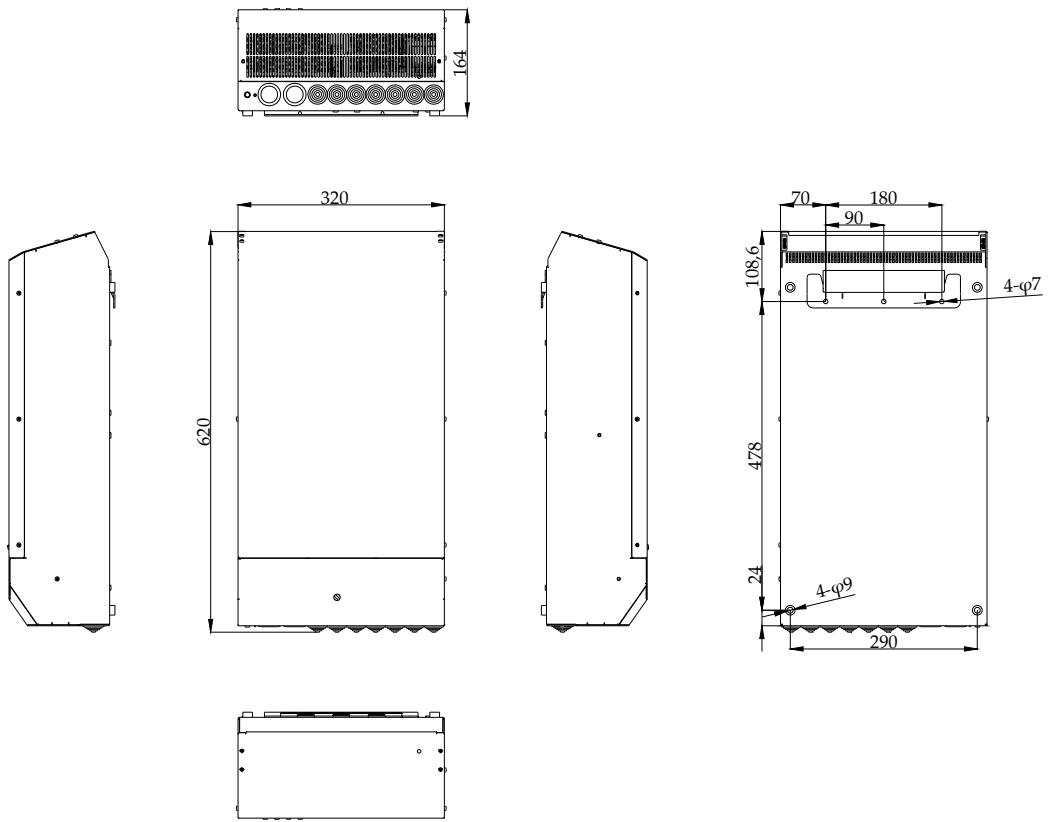

8KVA-S

Figure 2-4 Dimension of RiiO Sun II

2.3 Function

2.3.1 Power Control and Power Assist

RiiO Sun II offers a unique feature of power control & power assist, which is very useful when you have a limited grid supply or work with a generator. RiiO Sun II will take control of energy flow automatically, using extra power to charge the battery or discharge the battery to compensate the insufficient part of the grid or generator. With this feature, you can avoid air switch trip and do not have to use oversized generators.

2.3.2 Parallel and Three-phase

Two or more units can be connected in parallel to compose a single-phase parallel system or a three-phase parallel system, which is convenient for system expansion or to construct a micro-grid system. For a single-phase system, max 3 units can be connected in parallel. For a three-phase system, max 9 units can be connected together.

2.3.3 Work without Battery Mode

When working without battery, the loads connected to the AC output can be powered by AC bypass and PV energy. In this mode, the maximum power that the PV can provide is shown in the table below:

Model	2KVA-M 3KVA-M 3KVA-M-LV 3KVA-M-LV	3KVA-S 4KVA-S 3KVA-S-LV 4KVA-S-LV	5KVA-S 6KVA-S 8KVA-S
Maximum solar charge current when working without battery	40A	30A	50A

If the PV power is lower than the power requested by the load, and the AC bypass is connected, the power difference will be supplemented by the AC bypass.

2.3.4 Auto Restart While AC is Recovering

RiiO Sun II can automatically restart when the AC input (AC IN port only) is recovering. Full explanations are as follows:

While the lead-acid battery is under low-voltage protection, and once the AC input is recovering, RiiO Sun II can be woken up to recharge the battery (preconditions for wake-up: after the grid is regained, the battery voltage must be higher than the working voltage of RiiO Sun II's auxiliary source. For 48V model, the working voltage of its auxiliary source is 40V, and for 24V model the value is 20V).

While the lithium battery is under low-voltage protection, and once the AC input is recovering, RiiO Sun II can be woken up to recharge the lithium battery, and meantime the lithium battery can also be woken up to return to the normal state of charge and discharge.

2.3.5 Auto Restart While PV is Recovering

RiiO Sun II can automatically restart when the PV input is recovering. Full explanations are as follows:

While the lead-acid battery is under low-voltage protection, and once the PV input is recovering, the lead-acid battery can be charged by the MPPT module, and RiiO Sun II can be woken up at the same time.

While the lithium battery is under low-voltage protection, and once the PV input is recovering, the lithium battery can be charged by the MPPT module, so the lithium battery can be woken up to return to the normal state of charge and discharge, and meantime RiiO Sun II can also be woken up.

2.3.6 Powerful and Reliable Inverter

High Performance Pure Sine Wave

RiiO Sun II is a pure sine wave inverter generating a near perfect sine AC wave power output that is very similar to or even better than what you can get from your utility grid. Pure sine wave can guarantee the normal function of the sensitive equipment (computer, laser printer, TV, etc.). Also, your home appliances such as fridge, microwave and power tools will work more efficiently.

High Surge Power Capability

Provided with outstanding surge power capability and low frequency transformer, RiiO Sun II is suitable for heavy inductive loads like fridge, coffee maker, microwave, power tools, air conditioner, etc.

Battery Low Voltage/SOC Protection

RiiO Sun II provides configurable battery low voltage/SOC protection.

2.3.7 Professional Battery Charger

Battery Type Settings

RiiO Sun II supports working with lithium and lead-acid batteries. The current battery type and charging parameters can be displayed and set on the LCD screen.

No	Battery Type	Absorption charging voltage (Default)	Float charging voltage (Default)	Battery Default Charge Rate	Battery Maximum Charge Rate	EQ charging voltage
0	GEL/OPzV (Default)	14.1V (13.5~14.5V Configurable)	13.7V (13.0~14.0V Configurable)	0.15C	0.25C	-
1	AGM	14.4V (13.5~14.5V Configurable)	13.5V (13.0~14.0V Configurable)	0.15C	0.25C	-
2	Lead-Carbon	14.1V (13.5~14.5V)	13.5V (13.0~14.0V)	0.2C	0.5C	-

		Configurable)	Configurable)			
3	Flooded	14.7V	13.5V	0.15C	0.25C	Enable (15.5V)
4	Traction	15.2V	13.5V	0.15C	0.25C	Enable (16.2V)
5	Customized User-defined / Lithium Battery without Communication	13.3V (48V system) Configurable)	13.1V (48V system) Configurable)	0.3C	1.0C	-
6	TBB Lithium	BMS Communication Set (General Can Communication Protocol for Residential Energy Storage Industry) (The initial equalization voltage is 13.3V, and the float voltage is 13.0V; when the communication is established, it will follow the instructions from the BMS)				

Note: The above voltage is based on 12V battery voltage as a reference. For the 48V battery system, please multiply the given values by 4.

Multi Stage Sophisticated Charging Algorithm for Lead Acid Battery

Fitted with multistage charging algorithm (bulk-absorption-float-recycle), the built-in charger of Riio Sun II is designed to charge battery quickly and fully. A microprocessor-controlled charging algorithm with variable absorption charging timer could guarantee the optimal charging for the batteries of different discharged states.

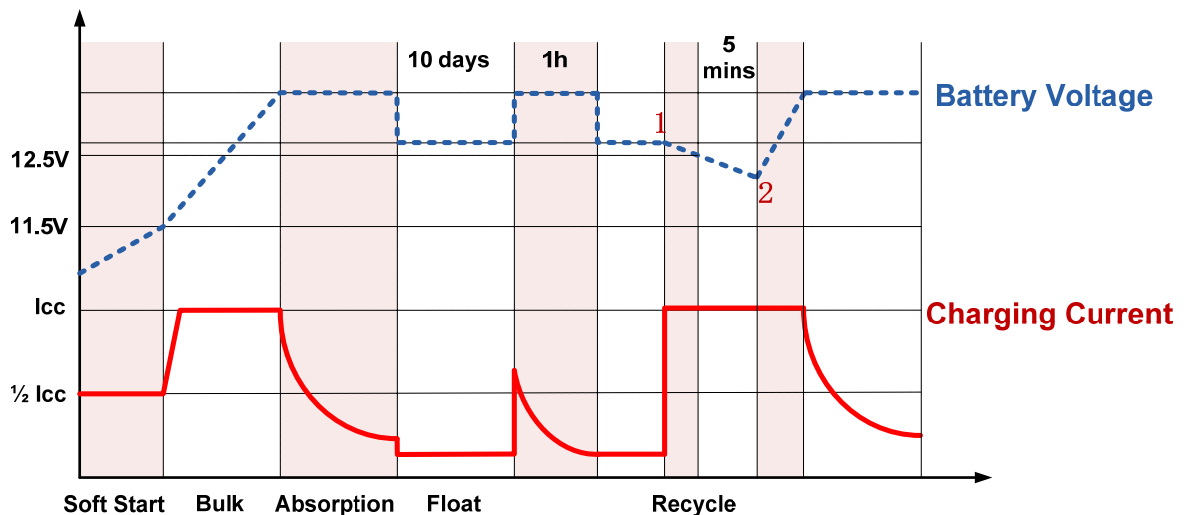

Figure 2-6 Multi Stage Sophisticated Charging Algorithm for Lead Acid Battery

Float and cycle charging program ensure that your battery is properly maintained over extended periods of connection to the inverter, reducing aging over extended periods of inactivity.

Multi Chemical Batteries Available

RiiO Sun II offers premium charging algorithm for the common chemical acid batteries, including AGM, GEL, Flooded, lead-carbon and Lithium battery. You can set the battery parameters through the LCD screen and the TBB Link software.

Compatible with Lithium Battery

RiiO Sun II supports working with general 48V lithium battery for residential energy storage.

Com Port Ver V1.0:

There are two ways to set up the connection between the lithium battery and RiiO Sun II, as described below:

1. Connect the 'ComSync In' port of the RiiO Li module (standard accessory) to the CAN port of the lithium battery.
2. Connect the 'ComSync In' port of the RiiO Mate module (optional accessory) to the CAN port of the lithium battery.

Com Port Ver V1.0:

Connect the 'ComSync In' port of the RiiO Sun II to the CAN port of the lithium battery.

When the connection with the lithium battery is set up, RiiO Sun II can automatically respond to the charging request of the lithium battery BMS, and meantime read the information sent by the lithium battery BMS for monitoring and display. When a communication error occurs after working with the lithium battery for a period of time, RiiO Sun II can automatically detect the error and raise an alarm.

Manual Equalization



It is strongly recommended to read this section carefully before you start the EQ charging and don't leave the battery unattended while performing desulfuration.



Always check if your battery supplier recommends the EQ charging. Only start when it is suitable.



If the battery type is set to AGM, GEL or Lead-Carbon, this charging profile can't be triggered on.

Over a period of time, the cells in a flooded battery will develop uneven chemical states. This will result in a weak cell which in turn can reduce the overall capacity of the battery. To improve the life span and performance of the flooded battery, RiiO Sun II provides a manual equalization program that can be used. If it is recommended by the battery manufacturer, you can initiate the desulfuration program manually. Once you trigger the equalization program, RiiO Sun II will perform equalization charging.

After 30 minutes, it will quit EQ charging and enter into float charging.

- Check the electrolyte level and refill the battery with the distilled water if necessary.
- If you want to return to normal charging, you need to stop equalization charging and switch off RiiO Sun II.
- Switch on RiiO Sun II again, then you will have your equipment back to normal charging.



During equalization, the battery generates potentially flammable gas. Follow all the battery safety precautions listed in this guide. Ventilate the area around the battery thoroughly and ensure that there are no sources of flame or sparks in the vicinity.



Turn off or disconnect all loads on the battery during equalization. The voltage applied to the battery during equalization may be above the safe levels for some loads.

Frequency:

For heavily used battery, you may need to equalize your battery once a month. For light-duty batteries, equalization is only required every 2-3 months.

Important:

- Equalization may damage your batteries if it is not performed properly. Always check battery fluid before and after equalization. Fill the batteries only with the distilled water.
- Always check the equalization switch is set back to OFF after each equalization.
- Follow the battery manufacturer's recommendations on equalization. Always follow the battery manufacturer's instructions to properly equalize the batteries. According to the guide, a heavily used battery may require equalization once a month while a battery with light duty service only needs equalizing once every 2 to 4 months.
- Battery type: as a protection, equalization charging can be performed if and only if you set the battery to Traction, Flooded or OPzS battery. If you choose the AGM, GEL or Lead-Carbon, EQ charging can't be performed.

2.3.8 Transfer

Uninterrupted AC Power Supply

In case of voltage/frequency/waveform of AC input match the minimum quality, the voltage will be switched directly to the AC output. RiiO Sun II will work as a battery charger and the loads will be powered by AC input. The voltage of the AC output and the AC input will be the same.

In case of the AC input failure or excessive AC input current, RiiO Sun II will initiate a fast take-over of power supply, which will guarantee an uninterrupted power supply. Once the AC input resumes or matches the quality, the power supply will be switched back to AC input again. Due to its ultra fast transfer design, as fast as 4ms, RiiO Sun II could be used as an UPS.

2.3.9 Feeding energy back into the grid

The feed-in grid function of RiiO Sun II can be enabled through relevant settings on its screen. If there is an external current meter, it can control the feeding power.

Notes: Please confirm whether RiiO Sun II meets the requirements of local grid regulations before enabling the feed-in grid function.

2.3.10 Protection Function

RiiO Sun II is equipped with a series of complete hardware and software protection functions to ensure its stable and reliable operation.

Overload Protection

When overload protection is triggered, it will restart automatically after 60s. And after three consecutive overload shutdown protections, RiiO Sun II will not restart automatically. In this case, the user needs to manually restart.

Over Temperature Protection

When the internal temperature is too high, RiiO Sun II will enter the over-temperature protection. After the internal temperature returns to normal, it can automatically resume normal operation.

Short Circuit Protection

RiiO Sun II will automatically shut down when the AC output is short-circuited and needs to be manually activated.

Battery Low Voltage/SOC Protection

To prevent the permanent battery damage caused by the over discharge of battery, RiiO Sun II will automatically cut off the output according to the low voltage/SOC protection threshold set by the user.

2.3.11 Communication

Dry Input Contact

RiiO Sun II is equipped with a dry input contact for remote on/off control.

Note: When the setting item '64-**Main switch selection**' is set to **Mobile Only mode**, the touch switch needs to be changed to a rocker switch.

RS485

Equipped with two RS485 ports.

ComSYS: System communication (RS485), connected to Solar Mate, or Meter.

ComMON: RS485 port for external monitoring such as Kinergy II, Ether Link, E4, etc.

2.3.12 ECO Mode

ECO Mode is to reduce the output power of the inverter while maintaining the normal use. When the battery capacity is insufficient or the SOC is in a low value, by setting the ECO Mode in the inverter, the power consumption of some specific loads can be reduced by 45% at max (30% on average), thereby prolonging the battery life. Press the UP and DOWN button at the same time to enter ECO MODE, exit the ECO MODE by the same operation.

2.3.13 Maximum Power Point Tracking

The output power of PV array is determined by the sun irradiation intensity and weather condition. The maximum power point varies a lot under different weather conditions.

Maximum Power Point Tracking technology maximizes the harvest of PV energy for charging the battery. The MPPT software algorithm will be continuously adjusted in accordance with the change of the sun irradiation intensity and weather condition, so as to find the maximum power point of the array. With MPPT, the user can maximize the usage of the PV energy.

2.3.14 Comprehensive Protection

RiiO Sun II is protected against many failures through hardware and software, making it robust and reliable.

PV Array Reverse Polarity Protection

RiiO Sun II will not work when PV reverse polarity is detected and the maximum PV short circuit current cannot exceed the specification regulated. After the PV is correctly wired, RiiO Sun II will work normally.



When the PV voltage exceeds the highest PV open circuit voltage range of RiiO Sun II, it may cause damage. Damage caused by improper use is not warranted.

3. Installation and Wiring

3.1 Pre-installation Inspection

3.1.1 Check Outer Packing

- Check the outer packaging for damage before unpacking, and check if this is the correct model. If there is something wrong, please don't open it and contact your dealer.
- Check the inner contents for any visible damage after unpacking.
- If any item is missing or there is any damage, please contact your dealer.

Table 3-1 Packing list

Packing list	
Description	Quantity
RiiO Sun II	1
User manual	1
Terminal SC10-6 (For connecting the ground wire)	1
Wall mount	1
Expansion bolt	5
M6 screw	5

3.2 Select Installation Location

3.2.1 Requirement

- The protection category of RiiO Sun II is IP21, so it can only be installed indoors.
- During the operation of the heat sink, the temperature of the case and heat sink will be relatively high. Please do not install it in the place where it is easy to reach.
- Do not install it in the place where inflammable and explosive articles are stored.
- Do not install it in the place where children can touch it.
- Do not install it on flammable building materials.
- Please make sure that the support surface is solid enough to bear the weight of RiiO Sun II.



Do not install RiiO Sun II in a sealed compartment containing batteries.

3.2.2 Installation Space Requirements

A good ventilation can guarantee the normal operation of equipment. Please always guarantee there is enough space around RiiO Sun II upon installation.

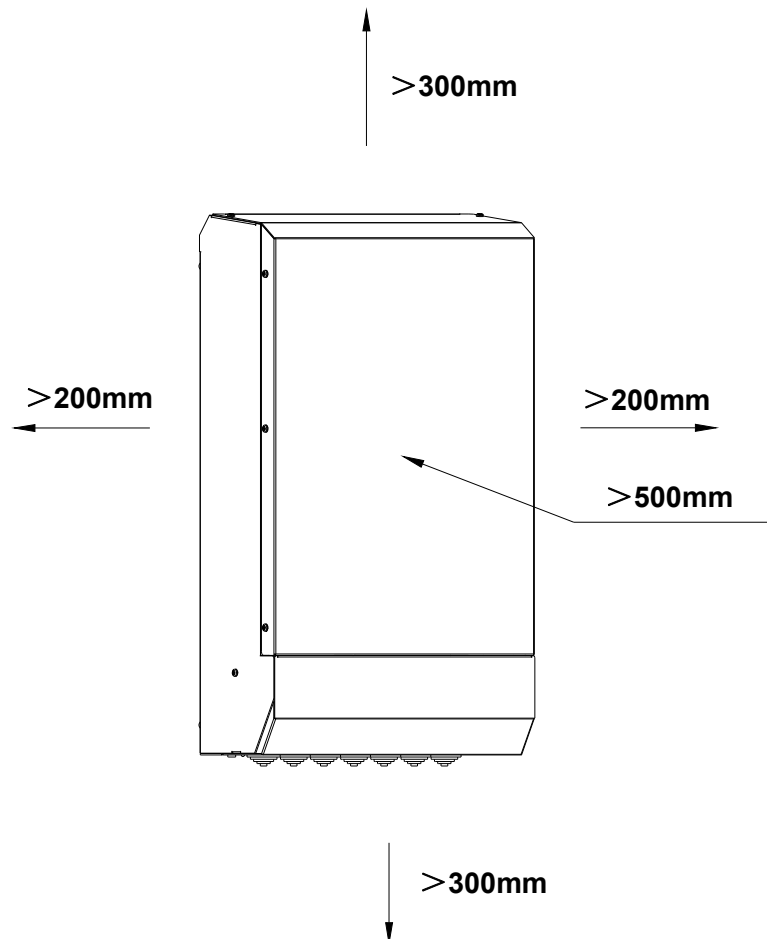

Figure 3-1 Installation space requirements

3.3 Installation

1. Find a flat solid wall surface. Use the wall-mount bracket as a template and drill 3 holes. Insert 3 expansion bolts after drilling. Fix the wall-mount bracket on the wall with 3 M6 self-tapping screws.
2. Remove the bottom cover of RiiO Sun II and mount RiiO Sun II onto the wall-mount bracket. Mark the positions of holes on the wall with a marker in accordance with the left and right mounting holes at the bottom of RiiO Sun II, and remove RiiO Sun II after the marking is made. Drill the 2 marked holes and mount RiiO Sun II onto the wall-mount bracket again after drilling.
3. Fix RiiO Sun II on the wall by securing the left and right mounting holes at the bottom of RiiO

Sun II with 2 M6 self-tapping screws.

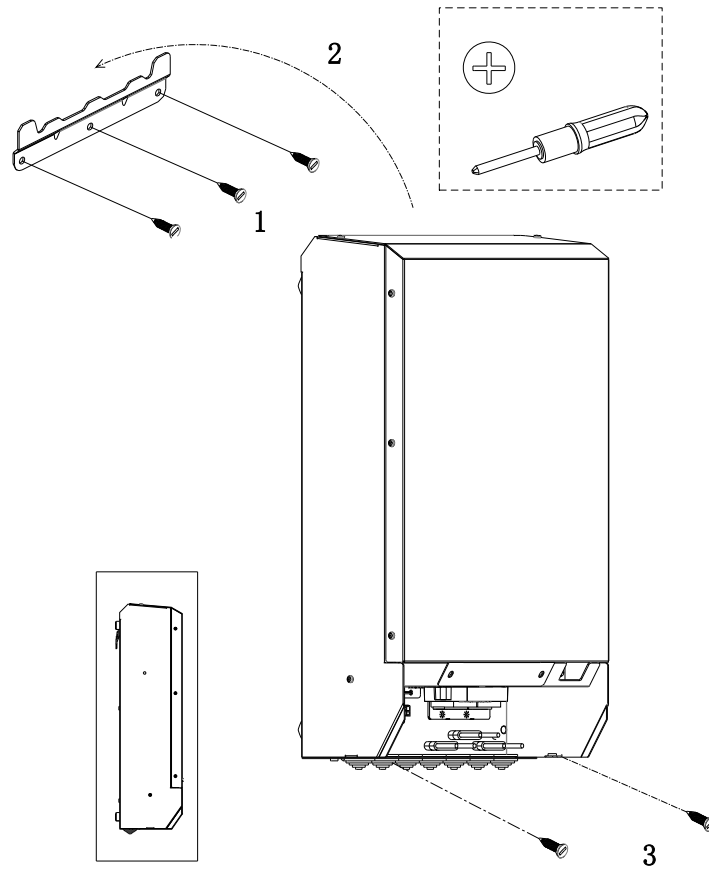

Figure 3-2 Illustration of installation



Please double check RiiO Sun II is securely installed.

3.4 Preparation Before Wiring

3.4.1 PV Array Preparation

Each RiiO Sun II must be connected to its own PV array. Please find following maximum PV array that can be connected under various DC systems.

The PV array configuration for RiiO Sun II 2KVA-M, 2KVA-M-LV, 3KVA-M and 3KVA-M-LV is recommended as follows:

Max. PV voltage (total Voc @ lowest temperature)	145V
Min. PV voltage (total Voc @ highest temperature)	40V
Max. PV current (total Isc @ highest temperature)	40A per tracker
Max. PV power (total Power @ STC)	3600W per tracker

The PV array configuration for RiiO Sun II 2KVA-S-LV, 3KVA-S, 3KVA-S-LV, 4KVA-S and 4KVA-S-LV is recommended as follows:

Max. PV voltage (total Voc @ lowest temperature)	245V
Min. PV voltage (total Voc @ highest temperature)	65V
Max. PV current (total Isc @ highest temperature)	40A per tracker
Max. PV power (total Power @ STC)	5200W per tracker

The PV array configuration for RiiO Sun II 5KVA-S, 6KVA-S and 8KVA-S is recommended as follows:

Max. PV voltage (total Voc @ lowest temperature)	245V
Min. PV voltage (total Voc @ highest temperature)	65V
Max. PV current (total Isc @ highest temperature)	40A per tracker
Max. PV power (total Power @ STC)	4400W per tracker

3.4.2 Breaker Preparation

- An over current protection device such as DC fuse or DC circuit breaker needs to be installed on positive cable rated at 125% of the nominal rating.
- The withstand voltage of the DC circuit breaker on the battery side should be greater than 63V.
- The withstand voltage of the DC circuit breaker on the PV array side should be greater than the PV open-circuit voltage.
- Circuit breaker requirements are shown in the Table 3-3.

Table 3-2 Breaker Requirement

NO.	Parts	Model	Requirement
1	Battery breaker	2KVA-M	(1) The voltage requirement should be greater than 63Vdc. (2) The current requirement should be greater than 100A.
		2KVA-M-LV	
		3KVA-M	(1) The voltage requirement should be greater than 63Vdc. (2) The current requirement should be greater than 150A.
		3KVA-M-LV	

		2KVA-S-LV	(1) The voltage requirement should be greater than 63Vdc. (2) The current requirement should be greater than 75A.
		3KVA-S 3KVA-S-LV	(1) The voltage requirement should be greater than 63Vdc. (2) The current requirement should be greater than 75A.
		4KVA-S 4KVA-S-LV	(1) The voltage requirement should be greater than 63Vdc. (2) The current requirement should be greater than 100A.
		5KVA-S	(1) The voltage requirement should be greater than 63Vdc. (2) The current requirement should be greater than 125A.
		6KVA-S	(1) The voltage requirement should be greater than 63Vdc. (2) The current requirement should be greater than 150A.
		8KVA-S	(1) The voltage requirement should be greater than 63Vdc. (2) The current requirement should be greater than 200A.
2	PV array breaker	2KVA-M 3KVA-M 2KVA-M-LV 3KVA-M-LV	(1) The voltage requirement should be greater than 150Vdc per tracker. (2) The current requirement should be greater than 40A per tracker.
		3KVA-S 4KVA-S 2KVA-S-LV 3KVA-S-LV 4KVA-S-LV	(1) The voltage requirement should be greater than 250Vdc per tracker. (2) The current requirement should be greater than 40A per tracker.
		5KVA-S 6KVA-S 8KVA-S	(1) The voltage requirement should be greater than 250Vdc per tracker. (2) The current requirement should be greater than 40A per tracker.
3	AC Breaker for AC IN, AC OUT and Smart Port	2KVA-M 3KVA-M 3KVA-S 4KVA-S	(1) The voltage requirement should be greater than 230Vac. (2) The current requirement should be greater than 32A.
		2KVA-M-LV 3KVA-M-LV 2KVA-S-LV 3KVA-S-LV 4KVA-S-LV	(1) The voltage requirement should be greater than 127Vac. (2) The current requirement should be greater than 50A.
		5KVA-S 6KVA-S 8KVA-S	(1) The voltage requirement should be greater than 230Vac. (2) The current requirement should be greater than 50A.

Note: The selection of the above circuit breakers or fuses must comply with the requirements of local laws and regulations.

3.4.3 Cable Preparation

- It is recommended to install RiiO Sun II with cables with insulation rating of at least Class Y (90°C).
- Minimum requirements on the cross-sectional area for the cables are shown in the Table 3-4.

Table 3-3 Recommended Battery wiring

Model	Recommended DC wiring			
	Length (The total length of the positive and negative cable of the battery)	4m	6m	10m
2KVA-M	Cross-sectional area	25mm ²	35mm ²	50mm ²
2KVA-M-LV	Voltage drop	0.5V	0.5V	0.6V
3KVA-M	Cross-sectional area	35mm ²	50mm ²	--
3KVA-M-LV	Voltage drop	0.5V	0.5V	--
2KVA-S-LV	Cross-sectional area	16mm ²	16mm ²	25mm ²
	Voltage drop	0.3V	0.4V	0.4V
3KVA-S	Cross-sectional area	16mm ²	25mm ²	35mm ²
3KVA-S-LV	Voltage drop	0.5V	0.5V	0.5V
4KVA-S	Cross-sectional area	25mm ²	35mm ²	50mm ²
4KVA-S-LV	Voltage drop	0.5V	0.5V	0.6V
5KVA-S	Cross-sectional area	35mm ²	50mm ²	70mm ²
	Voltage drop	0.4V	0.4V	0.5V
6KVA-S	Cross-sectional area	35mm ²	50mm ²	70mm ²
	Voltage drop	0.5V	0.5V	0.6V
8KVA-S	Cross-sectional area	50mm ²	70mm ²	--
	Voltage drop	0.5V	0.5V	--

3.5 Wiring

1. Connect the ground wire firmly.
2. Connect the corresponding communication cable according to the requirements of RiiO Sun II. When multiple units are to be connected in parallel, please replace the RiiO Li module with the RiiO Mate module (Com Port Ver V1.0).
3. Connect the Remote (port for remote on/off dry contact) signal cable and Relay (port for dry output contact) signal cable according to the requirements of RiiO Sun II.
4. Connect the corresponding battery sampling cable (optional) according to the requirements of RiiO Sun II.
5. Connect the positive and negative cables of the battery (! Pay attention to the positive and negative polarity of the battery. Make sure that a battery circuit breaker that meets the requirements of 3.4.2 has been installed between RiiO Sun II and the battery before performing the connection, and that the circuit breaker has been turned off.)
6. Connect the AC cables (! Pay attention to the wiring sequence of the cables. Make sure that an AC circuit breaker that meets the requirements of 3.4.2 has been installed between RiiO Sun II and AC input/output before performing the connection, and that the circuit breaker has been turned off.)

Connect the PV cables (! Pay attention to the positive and negative polarity of the PV array. Make sure that a PV array circuit breaker that meets the requirements of 3.4.2 has been installed between RiiO Sun II and the PV array before performing the connection, and that the circuit breaker has been turned off.)

7. After all wiring is completed, please fix the bottom cover back to RiiO Sun II with the screws.
8. For Appearance Ver V2.0, Kinergy II-WiFi can be installed right to the left side of the inverter.

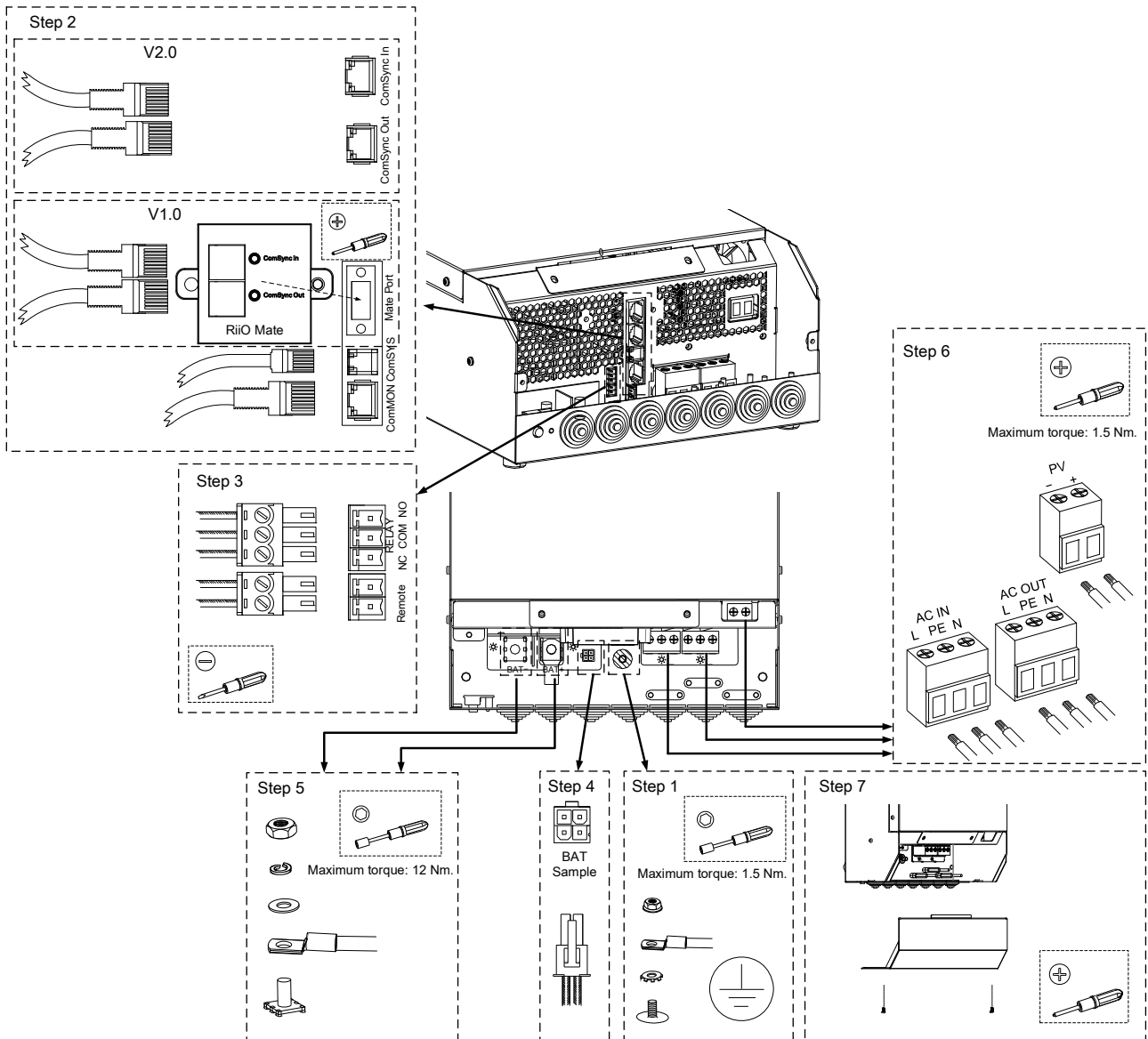

RiiO Sun II 2KVA-M, 3KVA-M, 3KVA-S, 4KVA-S

RiiO Sun II 2KVA-S-LV, 2KVA-M-LV, 3KVA-M-LV, 3KVA-S-LV, 4KVA-S-LV

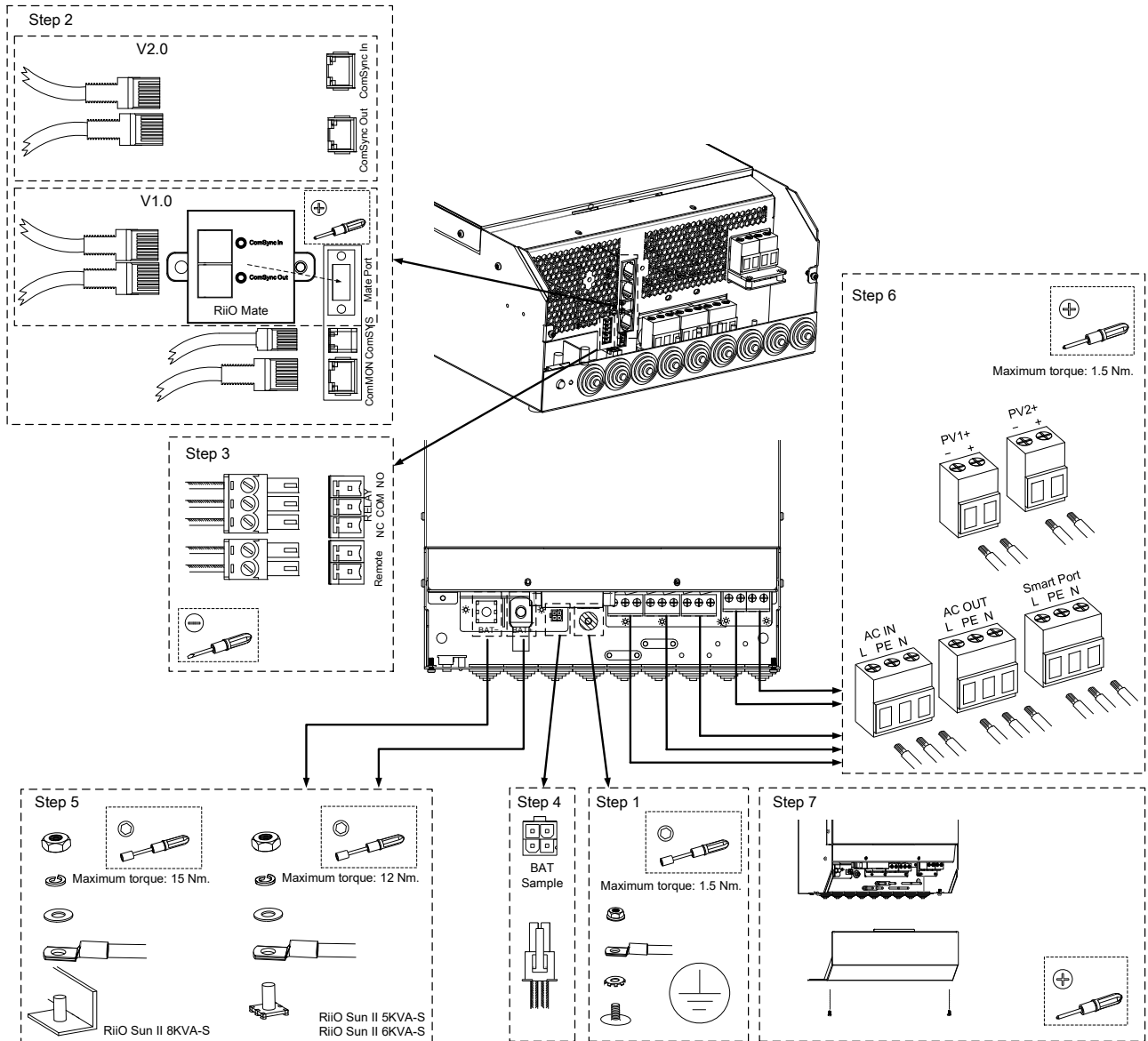

RiiO Sun II 5KVA-S, RiiO Sun II 6KVA-S, RiiO Sun II 8KVA-S

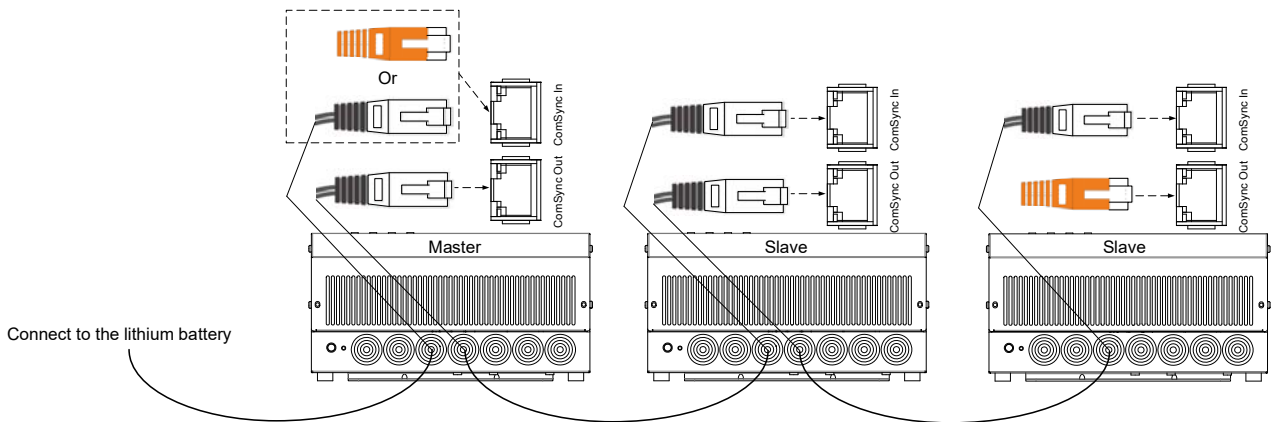

Step 2 For Parallel system, three phase system and communication with the lithium battery



-  8P8C communication cable
-  Resistance matching crystal

Figure 3-3 Illustration of wiring

4. Configuration

4.1 Check Before Operation

Please check before Operation according to the following.

- RiiO Sun II is installed correctly and firmly.
- Reasonable cable layout to meet customer requirements.
- Make sure the grounding is reliable.
- Make sure the ground wire is properly, firmly and reliably connected.
- Double check to make sure the battery breaker and PV array breaker is OFF.
- Make sure the cables are properly, firmly and reliably connected.
- Reasonable installation space, clean and tidy environment, no construction residue.

4.2 Power ON Test



Make sure the battery voltage and PV array voltage are within the permissible range before the breaker is turned ON.

Please follow the instructions step by step.

- Step 1: Turn on the circuit breaker between the PV array and RiiO Sun II.
- Step 2: Turn on the circuit breaker between the battery and RiiO Sun II.
- Step 3: Press the On/Off button for 2 seconds to turn on the inverter into the standby mode; the power LED will light up and the LCD will enter into the self test mode.
- Step 4: Wait in the standby mode for 30 seconds, then press the On/Off button again for 1 second to set the inverter to the inverting mode and observe the LCD display and Invert indicator to make sure the inverter is running normally.
- Step 5: Observe the LED indicators to make sure RiiO Sun II is running normally.

4.3 Power OFF



After RiiO Sun II is powered OFF, there is still residual power and heat on the case, which may lead to electric shock or burns. Therefore, 5 minutes after RiiO Sun II is powered off, you should wear protective gloves before removing RiiO Sun II.

Please follow the instructions step by step.

- Step 1: When the inverter is in the inverting mode or charging mode, press the On/Off button for 2 seconds to turn the inverter into the standby mode.
- Step 2: When the inverter is in the standby mode, press the On/Off button for 5 seconds to turn the inverter into the complete off mode.
- Step 3: Turn off the circuit breaker between the PV array and RiiO Sun II.
- Step 4: Turn off the circuit breaker between the battery and RiiO Sun II.

5. Operation

5.1 Operation and Display Panel

The operation and display panel includes four buttons and a LCD display, indicating the operating status and input/output power information.

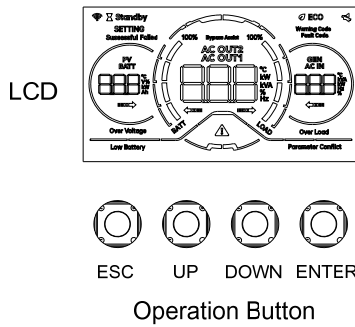

V1.0

- Invert
- Charge
- Fault

LED Indicator

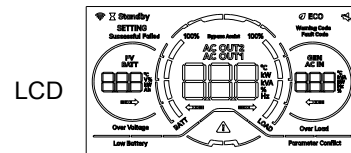

V2.0

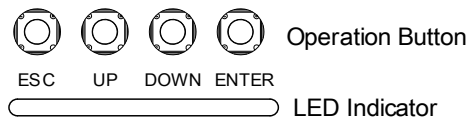

Button Function

Button	Function
	<ul style="list-style-type: none"> ➤ Short press <1s: To exit the setting mode or confirm the fault code. ➤ Short press <1s: Return to the previous screen from other interfaces.
	<ul style="list-style-type: none"> ➤ To go to the previous selection.
	<ul style="list-style-type: none"> ➤ To go to the next selection.
	<ul style="list-style-type: none"> ➤ Long press >2s: To enter the setting mode or confirm the selection. ➤ Short press <1s: Return to the previous screen from other interfaces.

LED Indicator V1.0

LED Indicator			Function
Invert	Green	Solid On	Inverting mode.
		Flashing	Power Assist mode or Bypass Assist mode.
Charge	Green	Solid On	The battery is charging.
		Flashing	The battery is fully charged.
Fault	Red	Solid On	Fault occurs.
		Flashing	Warning occurs.

Note: When working without battery, the Invert indicator and Charge indicator will flash simultaneously after the inverter is powered on.

LED Indicator V2.0

LED Indicator			Function
Invert	Blue	Solid On	Inverting mode.
		Flashing	Power Assist mode or Bypass Assist mode.
Charge	Green	Solid On	The battery is charging.
		Flashing	The battery is fully charged.
Warning	Yellow	Solid On	Warning occurs.
Fault	Red	Solid On	Fault occurs.
Standby	White	Solid On	Standby mode.

RiiO Sun II has a built-in buzzer with the following functions:

1. Beeping sound every time a button is pressed.
2. Beeping sound after the inverter completes the power-on self-test.
3. Beeping sound for enabling/disabling power level button.

The buzzer can be turned off when the silence mode is enabled.

5.2 Polling Interface on the Main Page



The main page mainly consists of three display areas: left, central and right. The contents displayed in each area are shown in the image below. When no operation is made, the contents of each area will be displayed cyclically at an time interval of 2s.

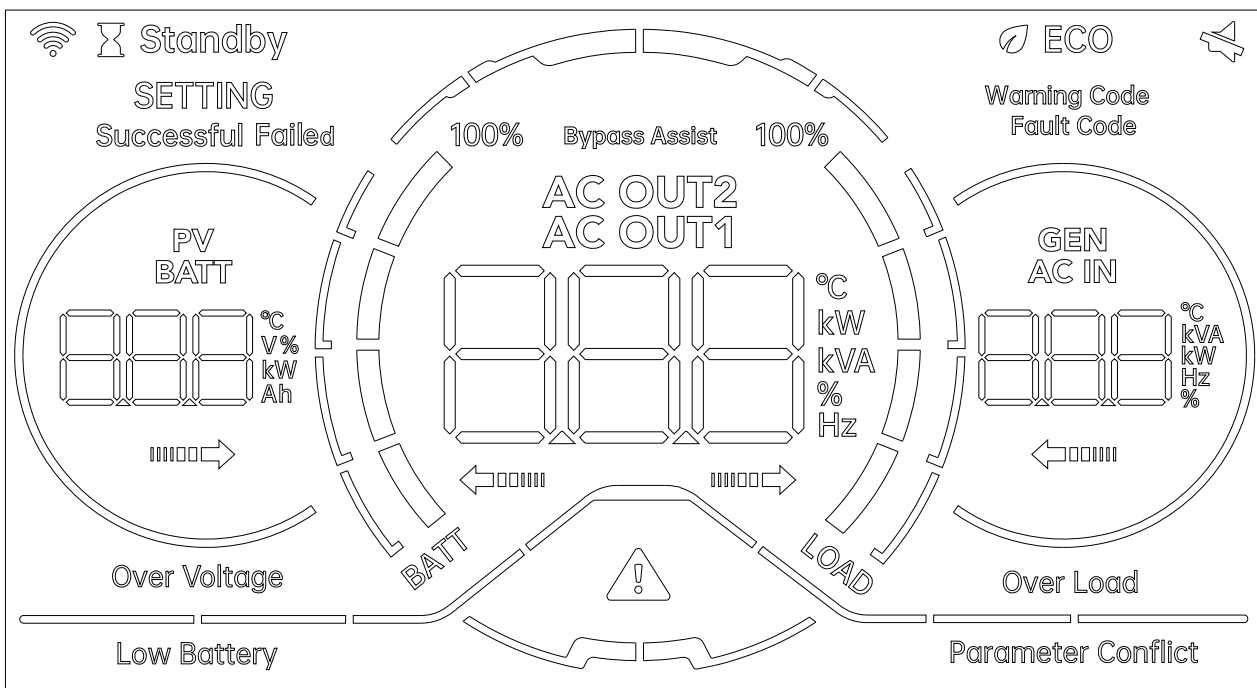

Short press the <Up> or <Down> button to quickly switch between the displayed content. The content displayed by manual switch is more than what can be displayed by automatic polling.

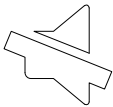
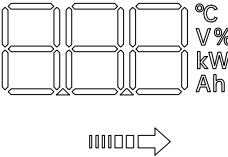
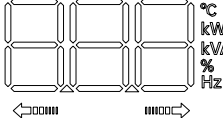

Left Display Area	Central Display Area	Right Display Area
PV voltage	AC Out1 voltage	AC IN input voltage
PV power	AC Out1 current	AC IN output current
Battery charge current	AC Out1 power	AC IN output power
Battery discharge current	AC Out2 voltage	AC IN frequency
Battery voltage	AC Out2 current	Generator output voltage
Battery SOC (Battery type: Lithium)	AC Out2 voltage	Generator output current
Battery temperature (Battery type: Lithium)	Percentage of load power	Generator output power
.....	Inverter frequency	Generator frequency

Explanations for each icon are provided in the table below.

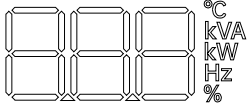
Icon	Explanation
	Indicates that RiiO Sun II is connected to Kinergy II or the upper computer.
 Standby	Indicates that RiiO Sun II is in standby mode.
SETTING Successful Failed	Indicates that RiiO Sun II is in setting mode, with the setting result displayed.
Bypass Assist	Indicates that RiiO Sun II is in Bypass Assist mode.
 ECO	Indicates that RiiO Sun II is in energy saving mode.
	Indicates that the silent mode is on.
PV BATT 	Left parameter display area Indicates the voltage, current, power, battery capacity, temperature, energy flow and other information related to the battery or PV.
AC OUT2 AC OUT1 	Central parameter display area Indicates the voltage, current, frequency, apparent power, active power, the percentage of power used to power loads, temperature, energy flow and other information related to the AC output.

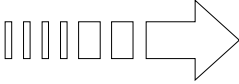
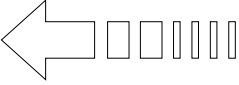
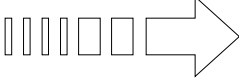
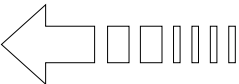
<p>GEN AC IN</p>  <p>←■■■■■</p>	<p>Right parameter display area Indicates the voltage, current, frequency, apparent power, active power, the percentage of power used to power loads, temperature and other information related to of the AC input.</p>
	<p>Indicates a fault or warning.</p>
<p>Warning Code Fault Code</p>	<p>Indicate the type of code, classified into warning code and fault code.</p>
<p>Over Voltage</p>	<p>Indicates that the battery is overvoltage.</p>
<p>Low Battery</p>	<p>Indicates that the battery is undervoltage.</p>
<p>Over Load</p>	<p>Indicates the output is overloaded.</p>
<p>Parameter Conflict</p>	<p>Indicates parameter conflict in a multi-unit system.</p>
<p>Energy flow indication: 4 arrows are displayed on the screen, defined as Arrow 1, Arrow 2, Arrow 3 and Arrow 4 from left to right.</p>	
 <p>Arrow 1</p>	<p>Battery page: Solid On: The battery is under discharging. PV page: Flashing: the PV energy is available but the MPPT has not begun to work. Solid On: the MPPT is running.</p>
 <p>Arrow 2</p>	<p>Battery page: Solid On: The battery is under charging.</p>
 <p>Arrow 3</p>	<p>AC OUT page: Solid On: There is AC output current from the AC OUT1 of RiiO Sun II. Smart Port page: Solid On: There is AC output current from the AC OUT2 of RiiO Sun II.</p>
 <p>Arrow 4</p>	<p>AC IN page: Flashing: The grid is available but it is not yet connected. Solid On: The grid is connected and working. Smart Port page: Flashing: The second AC input source is available but it is not yet connected. Solid On: The second AC input source is connected and working.</p>

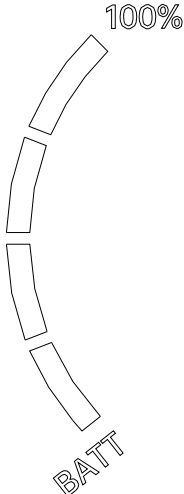
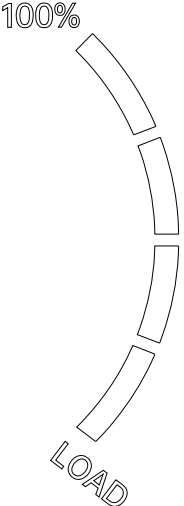
Battery information	
	<p>Indicates the battery status, and the display icons can be divided into:</p> <p>Charge mode: Indicates the SOC of battery. Discharge mode: Indicates the SOC of battery.</p> <p>SOC status 1: 0~3% SOC status 2: 4~24% SOC status 3: 25~49% SOC status 4: 50~74% SOC status 5: 75~100%</p> <p>Charge Mode SOC status 1: 4 bars will be off. SOC status 2: Bottom bar will flash and the other three bars will be off. SOC status 3: Bottom bar will be on and the second bar will flash. SOC status 4: Bottom two bars will be on and the third bar will flash. SOC status 5: Bottom three bars will be on and the top bar will flash.</p> <p>Discharge Mode SOC status 1: 4 bars will be off. SOC status 2: Bottom bar will be on and the other three bars will be off. SOC status 3: Bottom two bars will be on and the other two bars will be off. SOC status 4: Bottom three bars will be on and the top bar will be off. SOC status 5: 4 bars will be on.</p> <p>Low voltage alarm: the low voltage icon “Low Battery” will flash. Low voltage protection: the low voltage icon “Low Battery” will be solid on.</p>
Load information	
	<p>Indicates the current load status.</p> <p>Load status 1: 0~3%: 4 bars will be off. Load status 2: 4~24%: Bottom bar will be on and the other three bars will be off. Load status 3: 25~49%: Bottom two bars will be on and the other two bars will be off. Load status 4: 50~74%: Bottom three bars will be on and the top bar will be off. Load status 5: 75~100%: 4 bars will be on.</p> <p>Overload alarm: the overload icon “Over Load” will flash. Overload protection: the overload icon “Over Load” will be solid on.</p>

5.3 Quick Query Interface

On the main page, by short pressing the <Enter> button you can access the quick query page to view the phase sequence of each device and the device address in the phase when multiple devices are connected in parallel, as shown in the image below. Short press the <Up> or <Down> button to switch between the displayed content. Press the <Back> button and you will exit the page.

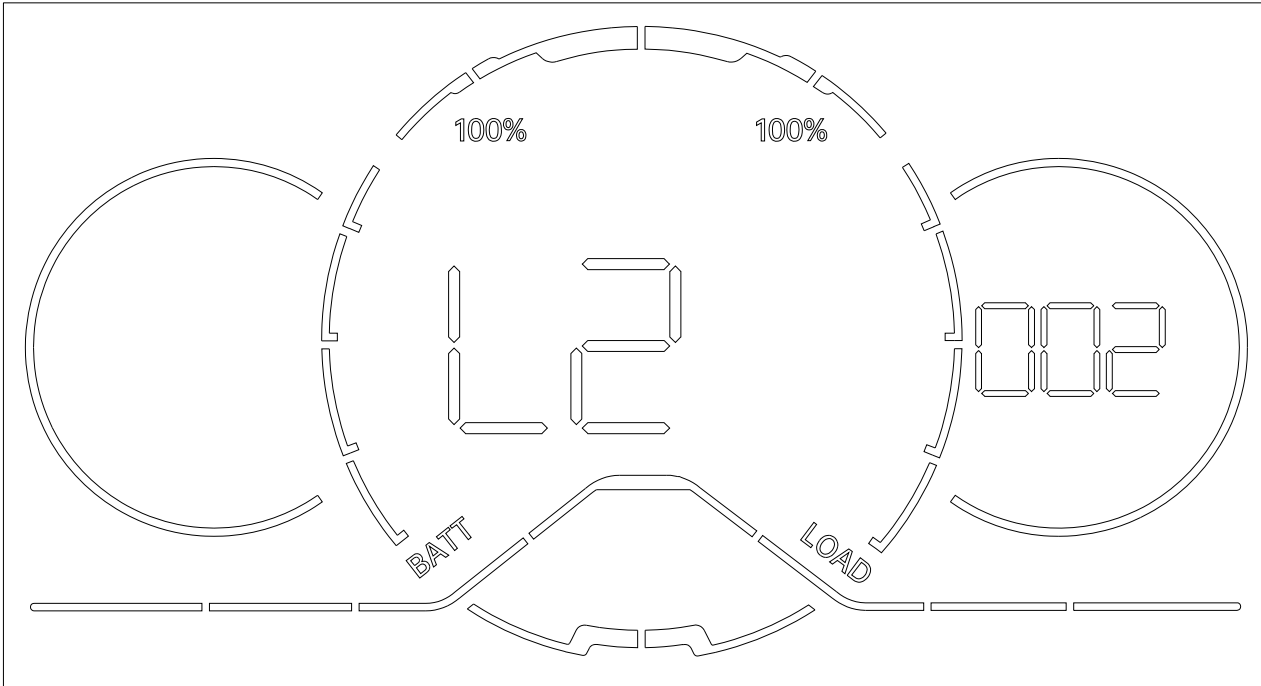

Left Display Area	Central Display Area	Right Display Area
	Phase sequence of the device L1: L1 Phase of the three phases L2: L2 Phase of the three phases L3: L3 Phase of the three phases	Device address 001: The first device in a phase 002: The second device in a phase 003: The third device in a phase

5.4 Fault/Warning Code Query Interface

On the main page, by short pressing the <Back> button you can access the fault code and warning code query page. Short press the <Up> or <Down> button to switch between different fault codes. For detailed explanations on fault codes, see section 5.2. Short press the <Back> button again and you will exit the page.

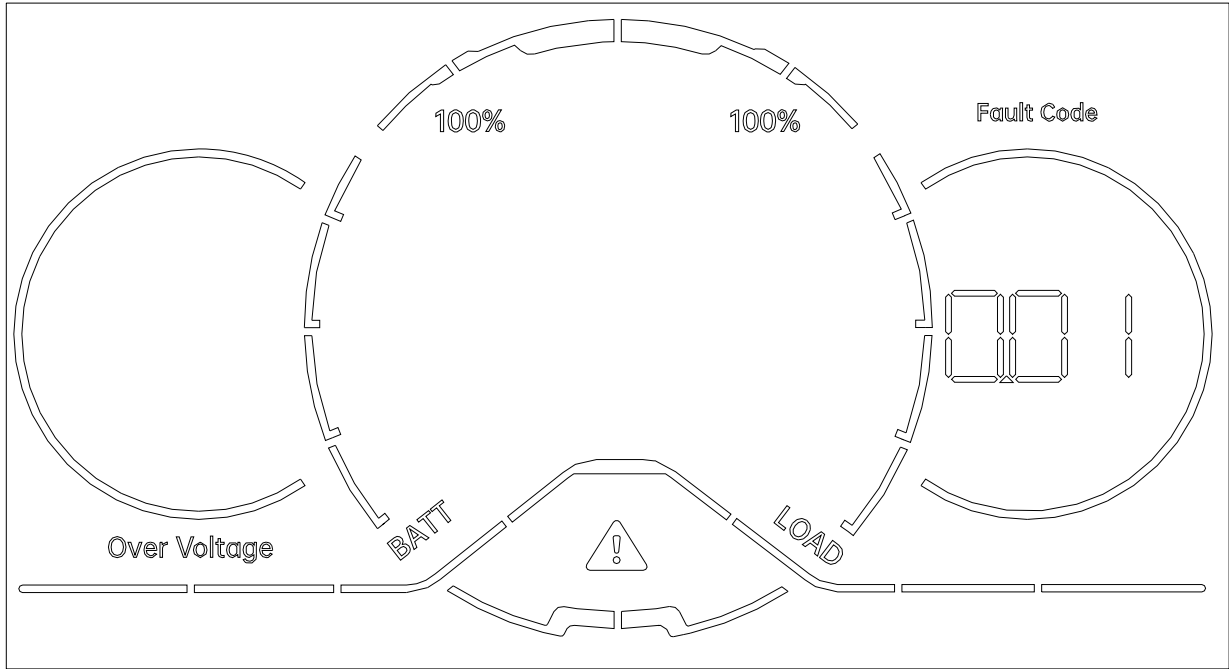

Left Display Area	Central Display Area	Right Display Area
		When "Fault Code" is indicated above the circle, the value displayed refers to the fault code. When "Warning Code" is indicated, the value displayed refers to the warning code.

5.5 Setting Interface

In the status display mode, long press the <Enter> button, and the LCD panel will enter the setting mode, as shown in the image below. After entering the setting mode, you can view the parameter values that were successfully set by the current items on the page. By pressing the <Up> or <Down> button, you can view the parameter values that were set by different items any time you want.

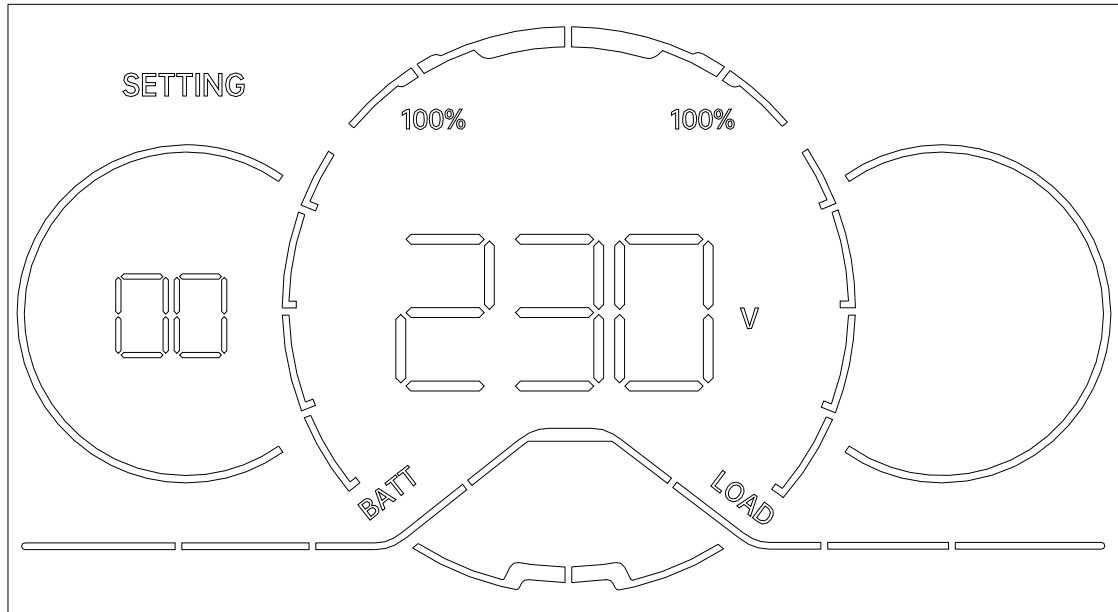

Left Display Area	Central Display Area	Right Display Area
Code of item	Value of item	

5.5.1 Instructions on Item Settings

When you are sure that an item needs to be modified, you can press the <Enter> button to make the modification in real time. By pressing the <Up> or <Down> button, you can modify the value of the parameter. If this setting cannot be adjusted in the current state, the SETTING icon on the panel will turn off (Adjustment is possible by setting the inverter to standby mode).

After the modification is made, press the <Enter> button to confirm your new setting, or you can press the <Back> button to cancel this action and return to the page for viewing the parameters.

The contents of the items are mainly displayed in the left and central display areas. "Left Display Area" displays the code, status and result of the item, while "Central Display Area" displays the corresponding value of the item. The process can be summarized into the following three steps:

(1) Enter the setting mode to select a specific item:

The "SETTING" icon is solid on.

Left Display Area: The outer circle flashes, and the digital tube displays the code of the item.

Central Display Area: The underline is solid on, and the digital tube displays the value corresponding to the item.

Press the <Up> or <Down> button to switch and view the code of different items.

Press the <Enter> button to enter the setting mode of a specific item.

(2) Enter the setting mode to modify a value:

The "SETTING" icon is solid on.

Left Display Area: The outer circle is solid on, and the digital tube displays the code of the item.

Central Display Area: The underline flashes, and the digital tube displays the value corresponding to the item.

Press the <Up> or <Down> button to modify the value.

Press the <Enter> button to confirm the value and make the setting.

(3) Confirm the setting:

The “SETTING” icon flashes, indicating that the current data is being sent. The buttons will not respond during the process until the setting is completed.

Left Display Area: The outer circle is solid on, and the digital tube displays the code of the item.

Central Display Area: The underline is solid on, and the digital tube displays the value corresponding to the item.

If the setting is successfully made, the “Successful” icon will be illuminated for 1s.

If the setting fails to be made, the “Fail” icon will be illuminated for 1s.

5.5.2 Parameter Code

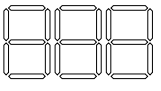
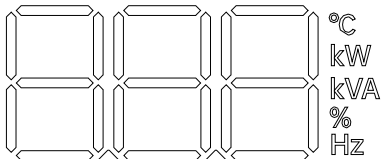
Parameter Code	Function	Description
Digital tube data display		
Left Display Area	Central Display Area	
		
Parameters for system settings		
00	Output voltage	220~240V@HV model Step: 10V Default: 230V 110V~127V@LV model Default: 120V
01	Output frequency	50~60Hz Step: 10Hz Default: 50Hz@HV model 60Hz@LV model (Can be set in standby mode ONLY)
02	Parallel mode	0-Stand-alone 1-Parallel 2-Three-Phase Default:0 (Can be set in standby mode ONLY)

03	Parallel phase	1-Phase-U (L1) 2-Phase-V (L2) 3-Phase-W (L3) Default: 1 (Can be set in standby mode ONLY under parallel and three-phase system)
04	Parallel address	1~3 Default: 1 (Can be set in standby mode ONLY under parallel system)
05	Synchronize parallel parameters	(The trigger will take effect with single press of <Enter> button) Default: 1 (Can be set in standby mode ONLY under parallel system)
06	Fault unlock	(The trigger will take effect with single press of <Enter> button) Default: 1
07	Number of MPPT	1-6 Default: 1 Note: The internal MPPT module is designated as the first one. If “N” additional external TBB Solar Mate units are added, the number will be set as “1+N”.
08	Battery full charge trigger	(The trigger will take effect with single press of <Enter> button) 0-Exit full charge status 1-Enter full charge status Default:0 (Can be set when Item 10 is set to 6, and item 40 is set to “SB”, “SBU”, “SUB”)
09	Work without battery mode	0-Disable 1-Enable Default: 0 (Can be set in standby mode ONLY)
Parameters for battery settings		
10	Battery type	0-GEL/OPzV 1-AGM 2-Lead-Carbon 3-Flooded 4-Traction 5-Customized 6-TBB Lithium Default:1-AGM (Can be set in standby mode ONLY)
11	Battery Ah	50~5000Ah Step: 50Ah Default: 200Ah (Can be set in standby mode ONLY)
12	Lithium battery communication protocol type	0-N/A (Not available for setting) 1-CAN 2-TBB 485 (When the battery type is set to 6, 1 or 2 can be selected)

13	Maximum charging current	5~Min{Maximum charging capacity of a single unit: battery Ah * charging rate} Step: 1A Default: 30A (This is the maximum charging current provided by AC bypass + PV together)
14	Absorption charging voltage (C.V voltage)	Refer to the equalization voltage range for different battery types. Step: 0.1V Default: 14.4V/(12V/cell) (≥Float charging voltage + 0.1)
15	Float charging voltage (C.F voltage)	Refer to the equalization voltage range for different battery types. Step: 0.1V Default: 13.5V/(12V/cell) (≤Bulk charging voltage - 0.1) (≥Battery low voltage alarm + 0.1)
16	Low battery alarm voltage	10.0~13.0V Step: 0.1V Default: 11.0V/(12V/cell) (≥Low battery protect voltage + 0.1) (≤Float charging voltage - 0.1)
17	Low battery protect voltage	9.5~12.5V Step: 0.1V Default: 10.5V/(12V/cell) (≤Low battery protect recover voltage - 0.1) (≤Low battery alarm voltage - 0.1)
18	Low battery protect recover voltage	11.0~14.0V Step: 0.1V Default: 13.0V/(12V/cell)
19	Low SOC alarm threshold	5~80% Step: 1% Default: 15% (≥Low SOC protection threshold + 1) (≤SOC enough threshold - 1)
20	Low SOC protection threshold	3~40% Step: 1% Default: 10% (≤Low SOC alarm threshold - 1)
21	BMS Float CHG EN When the battery type is set to TBB Lithium, this item can be set to maintain 2A float charging current when the lithium battery sends a 0A charging current command.	0-Disable 1-Enable Default: 1
22	BMS lower charge voltage	0~2.0V Step: 0.1V Default: 0V
23	Batt_DisCHG_Max_Cur	50~300 Step: 5A Default: 300A

24	Battery equalization control	0-OFF 1-ON Default: 0 (Can be set in float charging) (Available when battery type is set to 3-Flooded or 4-Traction)
25	Battery equalization voltage	15.5~16.3V Step: 0.1V Default: 15.5V/(12V/cell)
26	Battery equalized time	30~90min Step: 5min Default: 30min
Parameters for AC in settings		
30	AC in Source Selection	0-Grid 1-Generator Default: 0
31	Smart Port Modeset	0-Smart Load 1-Smart GEN Default: 1
32	AC in wave harmonic adaption	0-Normal 1-Weak AC input Default: 0
33	AC in Power Assist current	5~Max (Rated AC in current of RiiO Sun II) Step: 1A Default: Max
34	Smart GEN Power Assist current	5~ Max (Rated AC in current of RiiO Sun II) Step: 1A Default: Max
35	Maximum AC in charging current If the value instructed in Item 13 is lower than this, then the value of Item 13 will be used.	0~Max (Rated charging current of RiiO Sun II) Step: 1A Default: Max
36	Maximum Smart GEN charging current	0~Max (Rated charging current of RiiO Sun II) Step: 1A Default: Max

Parameters for mode settings		
40	AC in source priority	<p>USB: Solar energy charges the battery first and powers the loads if there is any surplus. RiiO Sun II is connected to the utility and provides supplementary power to charge the battery and power the loads.</p> <p>SB: Before battery voltage drops to low-level warning or RiiO Sun II is over temperature or overloaded, RiiO Sun II will not be connected to the utility.</p> <p>SBU: When grid power is connected to the RiiO Sun II, it prioritizes using DC to power the loads. If DC power is insufficient, the grid will help power the loads as supplements.</p> <p>SUB: Solar energy powers the loads first and charges the battery if there is any surplus. The utility provides supplementary power to the loads. The utility charges the battery only when battery voltage drops to low-level warning.</p> <p>TC: Time Control Mode, which set the inverter to operate in USB mode during the designated time window and in SB mode outside the time window. The time window can only be configured in the TBBLink upper computer or via the NOVA platform</p> <p>Default: USB</p> <p>The condition for low battery voltage is either a low voltage alarm or the content of settings 41, 42, or 43.</p>
41	Voltage back to utility when selecting "SBU" /"SB" / "SUB"	<p>10.0~12.5V Step: 0.1V Default: 11.0V/(12V/cell) (\geqLow battery protect voltage+0.1) (\leqFloating charging voltage - 0.1) (\leqVoltage back to battery when "SBU" / "SB" / "SUB" -0.5)</p>
42	Voltage back to battery mode when selecting "SBU" /"SB" / "SUB"	<p>12.0~14.4V Step: 0.1V Default: 13.0V/(12V/cell) (\geqVoltage back to utility when "SBU" / "SB" / "SUB" +0.5) (\leqBulk charging voltage - 0.1)</p>

43	Battery reserved capacity	15%~60% @ SBU 15%~90% @ SUB 15%~80% @ SB Step: 1% Default: 20%@SBU 80%@SUB 20%@SB
47	UPS Mode	0-Disable 1-Enable Default: 1 (Can be set in standby mode ONLY)
48	Common neutral line	0-Disable 1-Enable Default: 0 (Can be set in standby mode ONLY)
49	Connect Neutral to GND Inside	0-Disable 1-Enable Default: 1 (Can be set in standby mode ONLY)
Accessibility settings and version information		
50	Live date (year)	20~99 Default: N/A
51	Live date (month)	1~12 Default: N/A
52	Live date (day)	0~Max date of the month Default: N/A
53	Live time (hour)	0~23 Default: N/A
54	Live time (minute)	0~59 Default: N/A
55	Software version	(Read only)
56	Firmware version	(Read only)
57	Hardware version	(Read only)
59	LCD backlight keep-on enable	0-Disable (The screen will turn off automatically after 2 minutes of inactivity.) 1-Enable Default: 1
Parameters for advanced settings		
90	Advance set	Parameter initialization Password: 100 Default: 000 (Can be set in standby mode ONLY)
91	Remote control enable	0-Disable 1-Enable Default: 1
92	Remote update enable	0-Disable 1-Enable Default: 1
93	Silence mode enable	0-Disable 1-Enable Default: 0

6. FAQ

6.1 Fault Code

Fault Code	Fault Event	Solution
Inverter fault code		
01	DC bus is over voltage.	Check whether battery is well connected and whether there is any other connected charger that causes the battery overvoltage.
02	DC bus is under voltage.	Check whether battery wires are connected well.
03	Hardware protection against DC bus overvoltage	Check whether battery is well connected and whether there is any other connected charger that causes the battery overvoltage.
04	Auxiliary power supply is abnormal.	Restart RiiO Sun II. If the problem persists, please contact the after-sales service.
05	Heat sink's temperature is too high.	1. Check the ventilation of RiiO Sun II and whether the fan is working properly. 2. Check whether the air vent of the inverter is clear and unobstructed; check whether the ambient temperature exceeds 40°C.
06	Transformer's temperature is too high.	
07	Sampling is abnormal.	Restart RiiO Sun II. If the problem persists, please contact the after-sales service.
08	ROM storage is abnormal.	
09	Output is short circuited.	Check whether the connected load is short circuited at the AC output. Restart RiiO Sun II. If the problem persists, please contact the after-sales service.
10	Output is overloaded.	Check whether the AC output is overloaded and reduce the connected load. Restart RiiO Sun II. If the problem persists, please contact the after-sales service.
11	Cooling system is abnormal.	Check the ventilation of RiiO Sun II and whether the fan is working properly.
12	Battery is severely under voltage.	Manually restart the inverter and charge the battery by connecting it to an AC input source.
13	Output is under voltage.	Check whether the connected load is short circuited at the AC output. Restart RiiO Sun II. If the problem persists, please contact the after-sales service.
14	Instantaneous overcurrent	Check whether the connected load is short circuited at the AC output.
16	Relay is abnormal.	Restart RiiO Sun II. If the problem persists, please contact the after-sales service.
33	Ripple voltage on the battery is too high.	Check whether the battery connection is normal and whether the battery cable is too long.
MPPT fault code		
17	DC Bus is over voltage.	Check PV input voltage and wiring connection.

18	Battery is over voltage.	Check battery voltage and wiring connection at the output terminal.
19	Battery hardware is over voltage.	
20	Buck is short circuited.	Check if there is a short circuit at the MPPT output.
21	Buck 1 is over current.	Check the MPPT output connections and restart RiiO Sun II. If the problem persists, please contact the after-sales service.
22	Buck 2 is over current.	
23	Control Board's temperature is too high.	Check whether the air vent of the inverter is clear and unobstructed; check whether the ambient temperature exceeds 40°C.
24	Heat sink's temperature is too high.	
25	Auxiliary power supply is abnormal.	Restart RiiO Sun II. If the problem persists, please contact the after-sales service.
26	Auxiliary power supply is abnormal (hardware).	
27	Sampling is abnormal.	
28	ROM is abnormal.	

6.2 Warning code

Warning Code	Warning Event	Solution
Inverter warning code		
01	Battery is over voltage.	Check the battery voltage.
02	Battery is under voltage.	
03	Battery under voltage protection.	
04	Overload warning	Reduce the connected load at the AC output.
05	Heat sink NTC fails.	Power off RiiO Sun II completely, open the cover to check the internal NTC connection, and power on RiiO Sun II again. If the problem persists, please contact the after-sales service.
06	Transformer NTC fails.	
07	Battery temperature is too high.	Check battery sensor connection, check the battery temperature, and check the battery connections.
08	Fan is abnormal.	Power off RiiO Sun II completely, open the cover to check the fan connection, and power on RiiO Sun II again. If the problem persists, please contact the after-sales service.
09	The internal temperature of the inverter is too high	1. Check the ventilation of RiiO Sun II and whether the fan is working properly. 2. Check whether the air vent of the inverter is clear and unobstructed; check whether the ambient temperature exceeds 40°C.
10	CAN communication is abnormal.	Check the connection of the parallel communication cable. Check the parallel parameter settings.
11	Parallel address conflicts.	Check the parallel parameter settings (ID address).
12	Parameters do not match.	

13	Synchronization overtime	(Parameter Sync) Check the parallel parameter settings or trigger the Parameter Sync on the slave unit.
14	The system mode and the parameter settings do not match.	Check the inverter parameter settings (Smart Port).
15	Parallel system or three system's AC output is abnormal.	Check whether the AC output of each inverter is well connected in parallel.
16	Internal communication of LCD is abnormal.	Power off RiiO Sun II completely, open the cover to check the LCD wire connection, and power on RiiO Sun II again. If the problem persists, please contact the after-sales service.
17	Ripple voltage on the battery is too high.	Check whether the battery connection is normal and whether the battery cable is too long.
18	External meter is disconnected.	Check whether the connection between the meter and the RJ11 port of the inverter is normal.
AC input warning code		
20	AC input is over voltage.	Check the AC input source and the wiring connection.
21	AC input is under voltage/ Grid input does not exist.	
22	AC input is over frequency.	
23	AC input is under frequency.	
24	AC input phase sequence is abnormal.	
Self-test warning code		
30	Communication between the inverter and the DSP is abnormal.	Power off RiiO Sun II completely, open the cover to check the internal wiring connection, and power on RiiO Sun II again. If the problem persists, please contact the after-sales service.
31	Software and hardware matching error	Restart RiiO Sun II. If the problem persists, please contact the after-sales service.
BMS warning code		
40	Lithium module over voltage protection.	Consult the lithium battery supplier.
41	Lithium module under voltage protection.	Consult the lithium battery supplier.
42	Lithium module's temperature is too high.	Consult the lithium battery supplier.
43	Lithium module's temperature is too low.	Consult the lithium battery supplier.
44	Lithium module's discharge current is over normal value.	Consult the lithium battery supplier.
45	Lithium module's charge current is over normal value.	Consult the lithium battery supplier.
46	Lithium Battery Module fails.	Consult the lithium battery supplier.
50	Lithium module is over voltage.	Consult the lithium battery supplier.
51	Lithium module is under voltage.	Consult the lithium battery supplier.

52	Lithium module's temperature is too high.	Consult the lithium battery supplier.
53	Lithium module's temperature is too low.	Consult the lithium battery supplier.
54	Lithium module's discharge current is over normal value.	Consult the lithium battery supplier.
55	Lithium module's charge current is over normal value.	Consult the lithium battery supplier.
56	Communication with the inverter is abnormal.	Consult the lithium battery supplier.
57	Communication among Lithium modules is abnormal.	Consult the lithium battery supplier.
58	Lithium module's SOC is too low.	Consult the lithium battery supplier.
MPPT warning code		
62	MPPT current limitation alarm	Check if there is a short circuit at output.
64	Heat sink NTC fails.	Power off RiiO Sun II completely, open the cover to check the internal NTC connection, and power on RiiO Sun II again. If the problem persists, please contact the after-sales service.
66	Fan is abnormal.	Power off RiiO Sun II completely, open the cover to check the fan connection, and power on RiiO Sun II again. If the problem persists, please contact the after-sales service.
73	ROM read-write is abnormal.	Restart RiiO Sun II. If the problem persists, please contact the after-sales service.
79	Communication off line	Check the comm connection with the inverter, at a DC Coupled PV system
Smart Port warning code		
80	The second AC input is over voltage.	Check the AC input source and its connection. (Item 31: Smart Port Modeset is enabled when GEN is selected).
81	The second AC input is under voltage/ Generator input does not exist.	
82	The second AC input is over frequency.	
83	The second AC input is under frequency.	
84	The second AC input phase is abnormal.	

7. Specification

Series name	RiiO Sun II						
Model	2KVA-M	3KVA-M	3KVA-S	4KVA-S	5KVA-S	6KVA-S	8KVA-S
Power Assist	Yes						
AC input voltage range (VAC)	175~265						
AC input Frequency range (Hz)	45~65						
AC input Current (A)	32				50		
Inverter							
Nominal battery voltage (V)	24			48			
Input voltage range (V)	21-34			42~68			
AC output voltage (VAC)	220/230/240 ± 2%						
AC output Frequency (Hz)	50/60 ± 0.1%						
Harmonic distortion	<2%						
Load Power factor	1.0						
Cont. output power at 25°C (VA)	2000	3000	3000	4000	5000	6000	8000
Cont. output power at 25°C (W)	2000	3000	3000	4000	5000	6000	8000
Peak power (W)	4000	6000	6000	8000	10000	12000	16000
Maximum efficiency	91%	91%	93%	93%	94%	94%	95%
Zero load power (W)	13	17	17	19	22	25	32
Charger							
Charge voltage 'absorption' (V)	28.8			57.6			
Charge voltage 'float' (V)	27.6			55.2			
Battery types	AGM / GEL / OPzV / Lead-Carbon / Flooded / Traction / Lithium						
Max AC charge current (A)	40	70	35	50	60	70	90
Temperature compensation	Yes						
Solar Charge Controller							
Max output current (A)	80		60		100		
Maximum PV open circuit voltage (V)	150		250		250		
MPPT voltage range (V)	40~145		65~245		65~245		
Number of MPPT trackers	1		1		2		
Maximum PV input current per tracker (A)	36		36		36 + 36		
Maximum PV short circuit current per tracker (A)	40		40		40 + 40		
Allowable maximum PV panel power per tracker (W)	3600		5200		4400 + 4400		
Maximum efficiency	98%						
MPPT efficiency	>99.5%						
Protection	a) output short circuit, b) overload, c) battery voltage too high d) battery voltage too low, e) temperature too high, f) input voltage out of range						
General data							
AC Out1 Current (A)	32				50		
Smart Port Current (A)	N/A				50		
Transfer time	4ms (<15ms in Weak AC source Mode)						
Protection	a) output short circuit, b) overload, c) battery voltage too high, d) battery voltage too low, e) temperature too high, f) input voltage out of range, g) input voltage ripple too high, h) Fan block						
General purpose com. Port	RS485						
Configurable relay	1x (30Vdc/3A or 250Vac/3A)						
Operating temperature range	-20°C to 65°C						
Relative humidity in operation	95% without condensation						
Altitude (m)	2000						
Mechanical Data							
Dimension (mm) (max)	499*272*144				570*310*154		620*320*164
Net Weight (kg)	14	18	18	20	29	31	34
Cooling	Forced fan						
Protection index	IP21						
Standards							
Safety	EN-IEC 62477-1, EN-IEC 62109-1, EN-IEC 62109-2						
EMC	EN-IEC 61000-6-1, EN-IEC 61000-6-2, EN 61000-6-3, EN 61000-6-4, EN 61000-3-11, EN 61000-3-12						
Grid regulation	RD 1699						

Series name		RiiO Sun II				
Model	2KVA-M-LV	3KVA-M-LV	2KVA-S-LV	3KVA-S-LV	4KVA-S-LV	
Power Assist	Yes					
AC input voltage range (VAC)	85~140					
AC input Frequency range (Hz)	45~65					
AC input Current (A)	50					
Inverter						
Nominal battery voltage (V)	24		48			
Input voltage range (V)	21-34		42~68			
AC output voltage (VAC)	110/120/127 ± 2%					
AC output Frequency (Hz)	50/60 ± 0.1%					
Harmonic distortion	<2%					
Load Power factor	1.0					
Cont. output power at 25°C (VA)	2000	3000	2000	3000	4000	
Cont. output power at 25°C (W)	2000	3000	2000	3000	4000	
Peak power (W)	4000	6000	4000	6000	8000	
Maximum efficiency	91%	91%	93%	93%	93%	
Zero load power (W)	13	17	13	17	19	
Charger						
Charge voltage 'absorption' (V)	28.8		57.6			
Charge voltage 'float' (V)	27.6		55.2			
Battery types	AGM / GEL / OPzV / Lead-Carbon / Flooded / Traction / Lithium					
Max AC charge current (A)	40	70	20	35	50	
Temperature compensation	Yes					
Solar Charge Controller						
Max output current (A)	80		40	60		
Maximum PV open circuit voltage (V)	150		250	250		
MPPT voltage range (V)	40~145		65~245	65~245		
Number of MPPT trackers	1					
Maximum PV input current per tracker (A)	36		24	36		
Maximum PV short circuit current per tracker (A)	40		40	40		
Maximum PV power per tracker (W)	3600		3600	5200		
Maximum efficiency	98%					
MPPT efficiency	>99.5%					
Protection	a) output short circuit, b) overload, c) battery voltage too high d) battery voltage too low, e) temperature too high, f) input voltage out of range					
General data						
AC Out Current (A)	50					
Transfer time	4ms (<15ms in Weak AC source Mode)					
Protection	a) output short circuit, b) overload, c) battery voltage too high, d) battery voltage too low, e) temperature too high, f) input voltage out of range, g) input voltage ripple too high, h) Fan block					
General purpose com. Port	RS485					
Configurable relay	1x (30Vdc/3A or 250Vac/3A)					
Operating temperature range	-20°C to 65°C					
Relative humidity in operation	95% without condensation					
Altitude (m)	2000					
Mechanical Data						
Dimension (mm) (max)	499*272*144					
Net Weight (kg)	14	18	14	18	20	
Cooling	Forced fan					
Protection index	IP21					
Standards						
Safety	EN-IEC 62477-1, EN-IEC 62109-1, EN-IEC 62109-2					
EMC	EN-IEC 61000-6-1, EN-IEC 61000-6-2, EN 61000-6-3, EN 61000-6-4, EN 61000-3-11, EN 61000-3-12					

TBB Renewable (Xiamen) Co., Ltd.

 TBBsupport@tbbrenewable.com

 www.tbbrenewable.com

 +86-592-5796068 /5796287

 +86-592-5796070